

# MODEL 32905-L OUTLINE DIMENSIONS

REVISIONS			
LTR	DATE	DESCRIPTION	BY
E	1/24/05	7 3/4 TO MTG HOLES WAS 8 TO CL OF PORT; 2 13/16 TO CL FLANGE WAS 2 13/16 -ECN 6018	DAC
F	2/17/05	UPDATED TO SHOW NEW COUNTERWEIGHT & TOP CAP PER ECN 6063	DAC
G	3/3/05	UPDATED TABULATION: MODEL 32905-L VOLUME WAS 460 CU. IN.; ADDED PERCENTAGE ROW PER ECN 6099	DAC
H	4/8/05	REMOVED ALL 32906-L/50 DIM; REMOVED TABULATED CHART PER ECN #6157	RJD DAC
J	11-10-06	CHANGE P/N CALLOUT 32440L WAS 32886 #D-4 PER ECN 7342	RAL

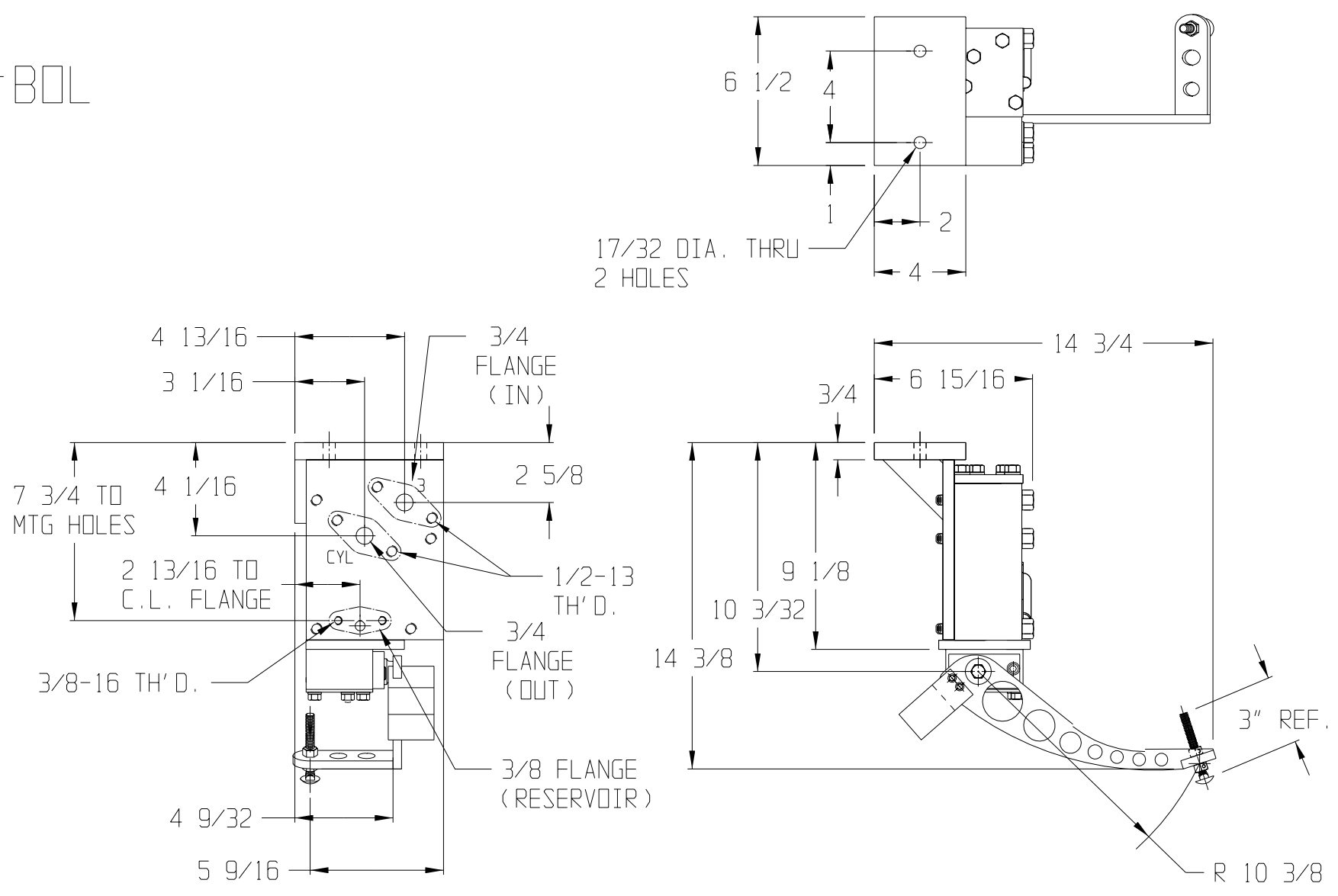
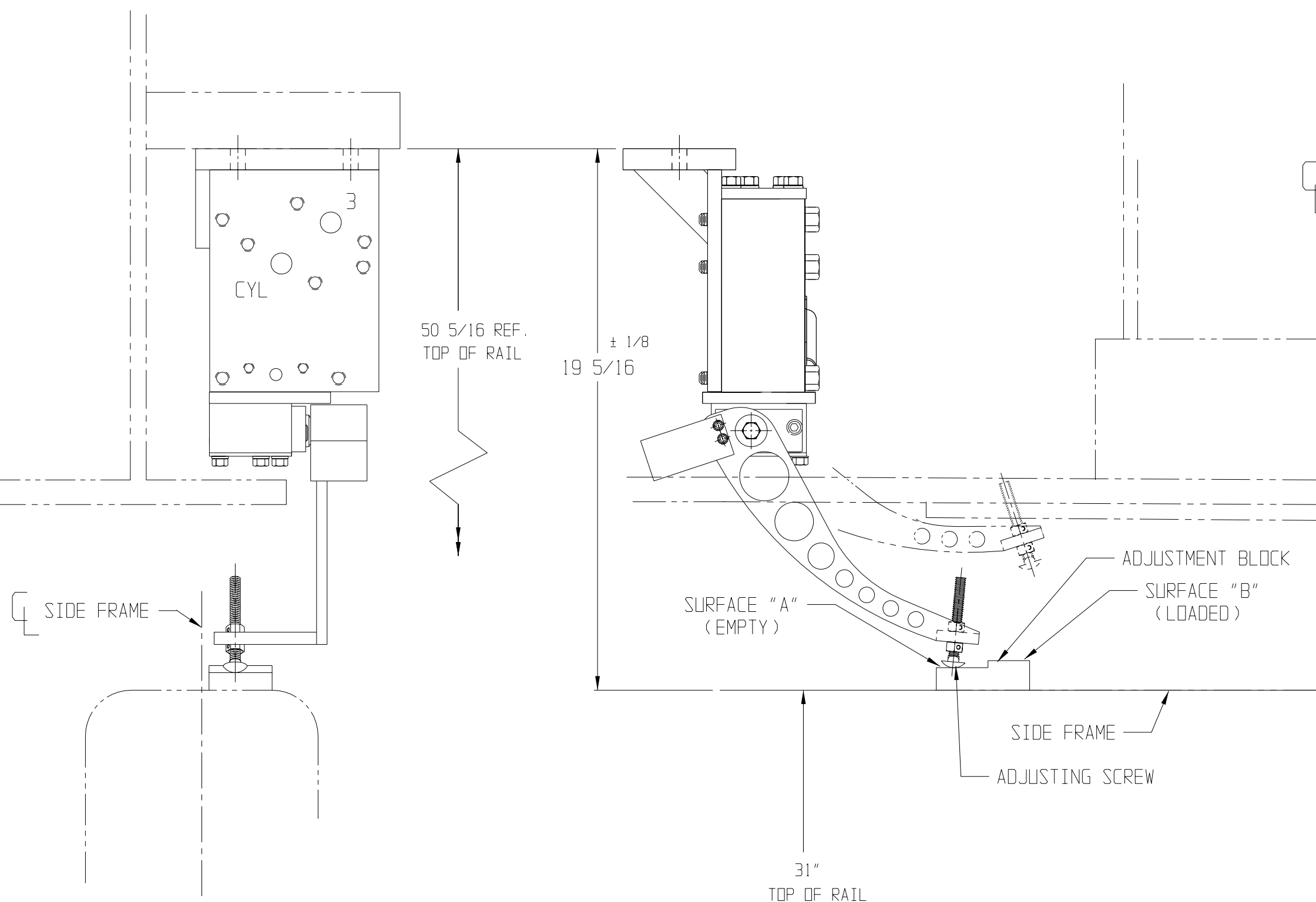

## RESERVOIR OUTLINE DIMENSIONS

P/N 32440L  
435 CU IN VOLUME

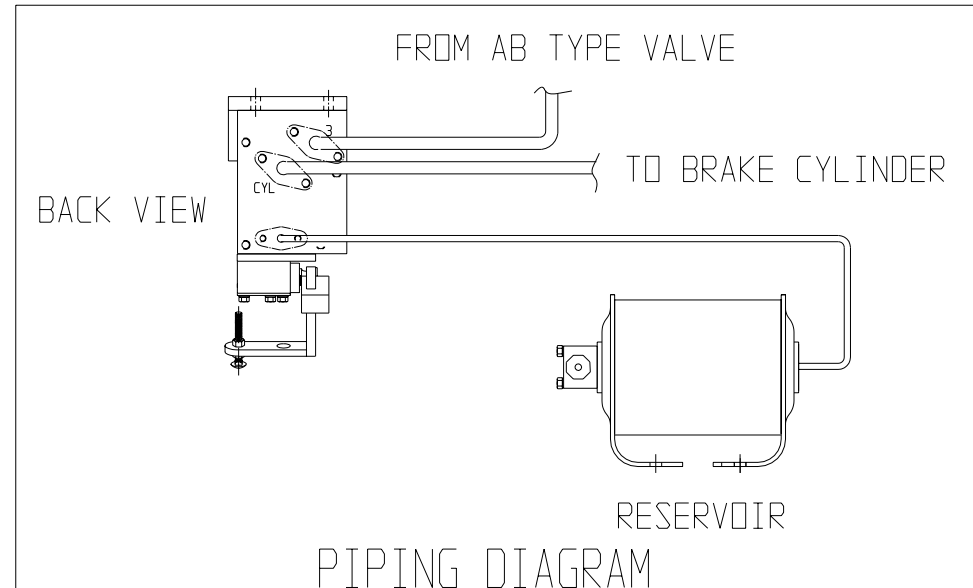
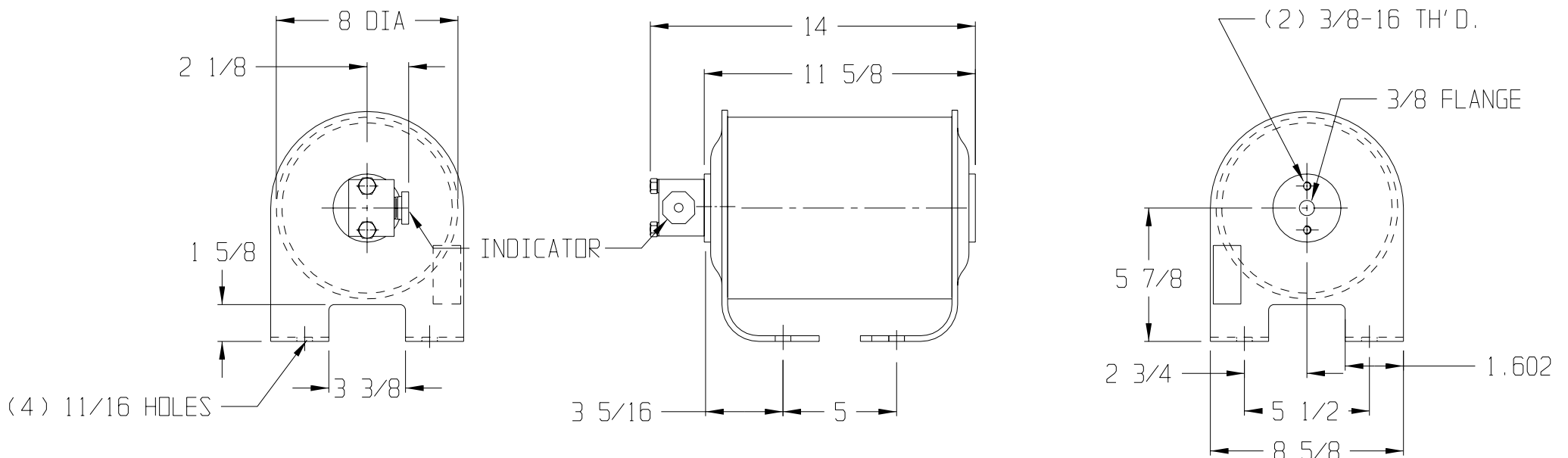

## NEW CAR INSTALLATION

1. SPRING TRAVEL BETWEEN LIGHT AND LOADED CAR 2 5/16 MAX. AND 1 7/8 MIN.
2. HEIGHT:  
THE MOUNTING HEIGHT SHOULD BE INCREASED FOR LUBRICATION PADS (1/8" RECOMMENDED) PLUS ALLOWANCE FOR NEW CAR SETTLING (1/4" MAX. RECOMMENDED)

## ADJUSTMENT

1. ADJUSTMENT MUST BE DONE ON AN EMPTY CAR AND LEVEL TRACK (APPROX. 9 3/4 SPRING HEIGHT)
2. ADJUSTMENT BLOCK THICKNESS TO BE 1/5 THE SPRING DEFLECTION BETWEEN A LIGHT AND A LOADED CAR. ON A NEW CAR FOR WHICH THE MOUNTING HEIGHT HAS BEEN INCREASED FOR LUBRICATION PADS AND CAR SETTLING. THE ADJUSTMENT BLOCK SHOULD BE INCREASED A LIKE AMOUNT.

## PROCEDURE FOR ADJUSTMENT

1. PLACE ADJUSTMENT BLOCK ON SIDE FRAME OR CONTACT SURFACE DIRECTLY BELOW CONTACT POINT OF ADJUSTING SCREW. (ADJUSTING SCREW SHOULD BE FULLY EXTENDED).
2. WITH BRAKES APPLIED (45 PSI MIN. B.C. PRESSURE) ADJUST CONTACT ADJUSTING SCREW UNTIL INDICATOR IS SEEN PROTRUDING FROM RESERVOIR. ADJUSTING SCREW SHOULD BE TOUCHING SURFACE "A". (AS SHOWN)
3. RELEASE BRAKES AND SLIDE ADJUSTING BLOCK SO THAT ADJUSTING SCREW WILL CONTACT SURFACE "B" WHEN BRAKES ARE APPLIED. APPLY BRAKES, INDICATOR SHOULD NOT PROTRUDE FROM RESERVOIR (NOT SHOWN).
4. TIGHTEN LOCK NUTS.
5. VALVE OPERATION MUST PASS A.A.R. SINGLE CAR CODE OF TESTS BEFORE THE CAR IS RELEASED FOR SERVICE.

THIS DOCUMENT AND ITS CONTENTS CONTAIN CONFIDENTIAL AND PROPRIETARY INFORMATION OWNED BY ELLCON-NATIONAL, INC. AND IT AND ALL COPIES THEREOF ARE TO BE RETURNED TO ELLCON-NATIONAL WHEN SO REQUESTED. THIS DOCUMENT OR ANY PART THEREOF SHALL NOT BE REPRODUCED, COPIED, OR TRANSMITTED ELECTRONICALLY. THE INFORMATION CONTAINED HEREIN SHALL NOT BE DISCLOSED BY THE RECIPIENT TO OTHERS OR USED BY RECIPIENT WITHOUT THE PRIOR WRITTEN CONSENT SPECIFIC TO EACH CASE. ELLCON-NATIONAL, INC.

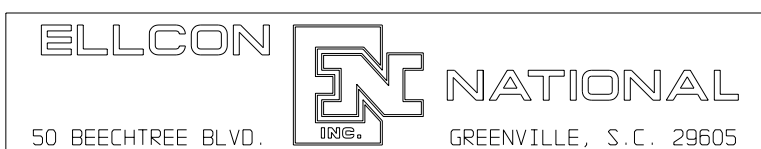

## 32905-L E/L DEVICE OUTLINE DIMENSIONS

SCALE NONE	DATE 9-29-94	REV.
DRAWN D. BRUSHWOOD	C-32955	J
CHECKED		