

REVISIONS				
ZONE	REV.	DESCRIPTION	DATE	BY
		ISSUED PER ECN 6792	2/20/06	
	A	(C-9) CHANGED LOCATION OF SENSOR SCREW FROM 2 ³ / ₈ TO 2 ⁵ / ₈ NOMINA ; (E-9) CHANGED SCREW LENGTH TO END OF HEAD FROM FLAT OF HEAD; REMOVED "APPROX" FROM OVERALL DIMENSIONS (SEE NOTE 3); (C-9) ADDED BRACKET FLANGE THICKNESS 1 ¹ / ₁₆ ; CHANGED LOCK WASHER FROM 3391-41 TO 3391-11; (D-5) ADDED 1.09 CLEARANCE DIMENSION; PER ECN 7590	2/14/2007	SDM
	B	REMOVED UNDISPLAYED PARTS FROM BOM DISPLAY PER ECN 7779	5/7/2007	SDM
	C	REPLACED PLASTIC PROTECTOR 4087-48 WITH 4087-51 PER ECN 7909	7/12/2007	SDM
	D	ADDED RED THREADLOCKER TO ITEMS 3 AND 4; PER ECN 7946	8/7/2007	SDM
	E	PICTORIALLY REVISED TO SHOW NAMEPLATE; PER ECN 8189	12/7/2007	sdm

NOTES:

- SEAL EXPOSED HOLES OF PIPE BRACKET (ITEM 2) WITH PLASTIC PROTECTORS AND SEAL EXPOSED HOLE IN BOTTOM OF SIDE CAP WITH A SMALL PIECE OF TAPE BEFORE PRIMING & SHIPPING. DO NOT USE GLUE.
- ASSY TO BE COATED WITH A BLACK, WATER REDUCIBLE PRIMER.
- ALL DIMENSIONS ARE NOMINAL AND FOR REFERENCE ONLY.
- CUSTOMER TO REMOVE ALL (3) PLASTIC PROTECTORS AND TAPE ON BOTTOM OF SIDE CAP AFTER CAR BLASTING AND BEFORE AIR TESTING.
- APPLY RED THREADLOCKER (LOCTITE NO. 242 OR EQUIV) TO THREADS OF ITEMS 3 AND 4.

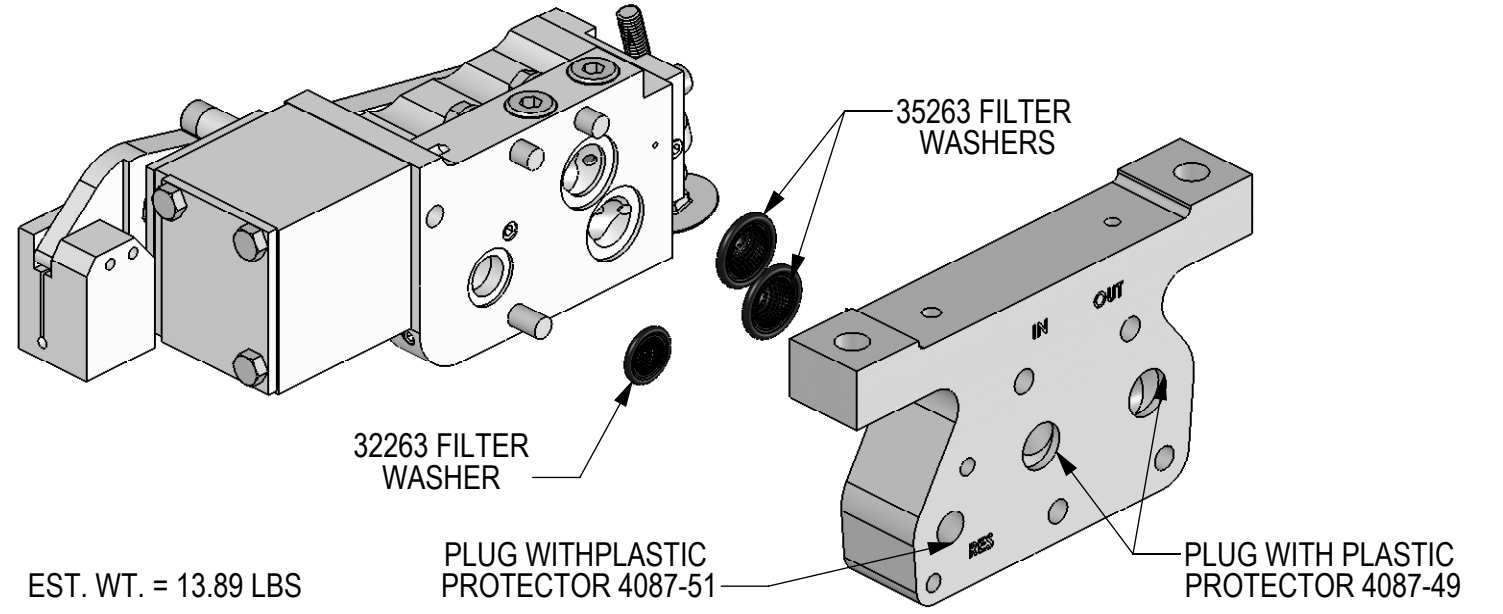

EST. WT. = 13.89 LBS

THIS DOCUMENT AND ITS CONTENTS CONTAIN CONFIDENTIAL AND PROPRIETARY INFORMATION OWNED BY ELLCON-NATIONAL, INC. AND IT AND ALL COPIES THEREOF ARE TO BE RETURNED TO ELLCON-NATIONAL WHEN SO REQUESTED. THIS DOCUMENT OR ANY PART THEREOF SHALL NOT BE REPRODUCED, COPIED, OR TRANSMITTED ELECTRONICALLY. THE INFORMATION CONTAINED HEREIN SHALL NOT BE DISCLOSED BY THE RECIPIENT TO OTHERS OR USED BY RECIPIENT WITHOUT THE PRIOR WRITTEN CONSENT SPECIFIC TO EACH CASE. ELLCON-NATIONAL, INC.

LEGEND	
∅ - DIAMETER	▭ - FLATNESS
▽ - DEPTH	// - PARALLELISM
┌ - COUNTERBORE	⊥ - PERPENDICULARITY
∨ - COUNTERSINK	◎ - CONCENTRICITY

TOLERANCES AND FINISHES UNLESS OTHERWISE NOTED

DECIMALS .XX ±
 DECIMALS .XXX ±
 ANGLES ±
 FRACTIONS ±
 DRILLED HOLE DIAMETERS +.010/-0.01
 BREAK ALL SHARP CORNERS AND EDGES
 C'SK ALL TAPPED HOLES 118° x ONE THREAD DEEP
 MACHINED SURFACES 125 ✓

MATERIAL:	
35250	ENX-50R
NEXT ASSY	USED ON



VALVE & PIPE BRKT ASSY
P/N 35280

SCALE 1:2	DATE 2/20/2006	REV.
DRAWN D.CARROLL	B-35280	E
CHECKED		

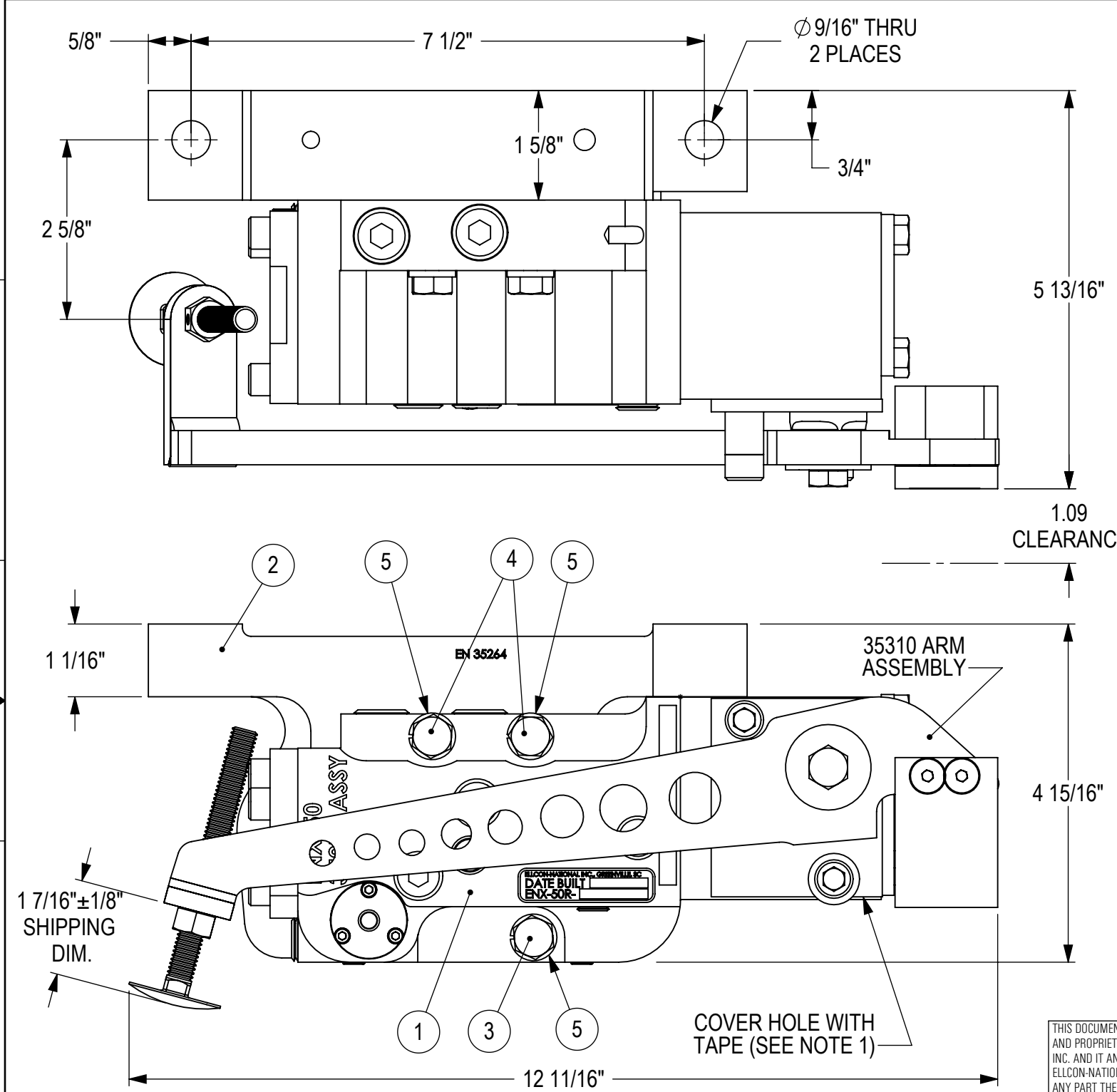

ITEM NO.	PART NUMBER	DESCRIPTION	QTY.
5	3391-11	LOCKWASHER (3/8", ZN PLTD)	3
4	3442-183	HEX BOLT (3/8-16 X 1 1/2, GR5, ZN PLTD)	2
3	3442-51	HEX BOLT (3/8-16 X 1 1/4, GR5, ZN PLTD)	1
2	35264	PIPE BRACKET	1
	35310	SENSOR ARM ASSY	1
	35263	FILTER WASHER (1 1/4" OD)	2
	32263	FILTER WASHER (.980" OD)	1
1	35270	VALVE ASSY	1