

REVISIONS				
ZONE	REV.	DESCRIPTION	DATE	BY
		ISSUED PER ECN 7895	7/3/2007	SDM

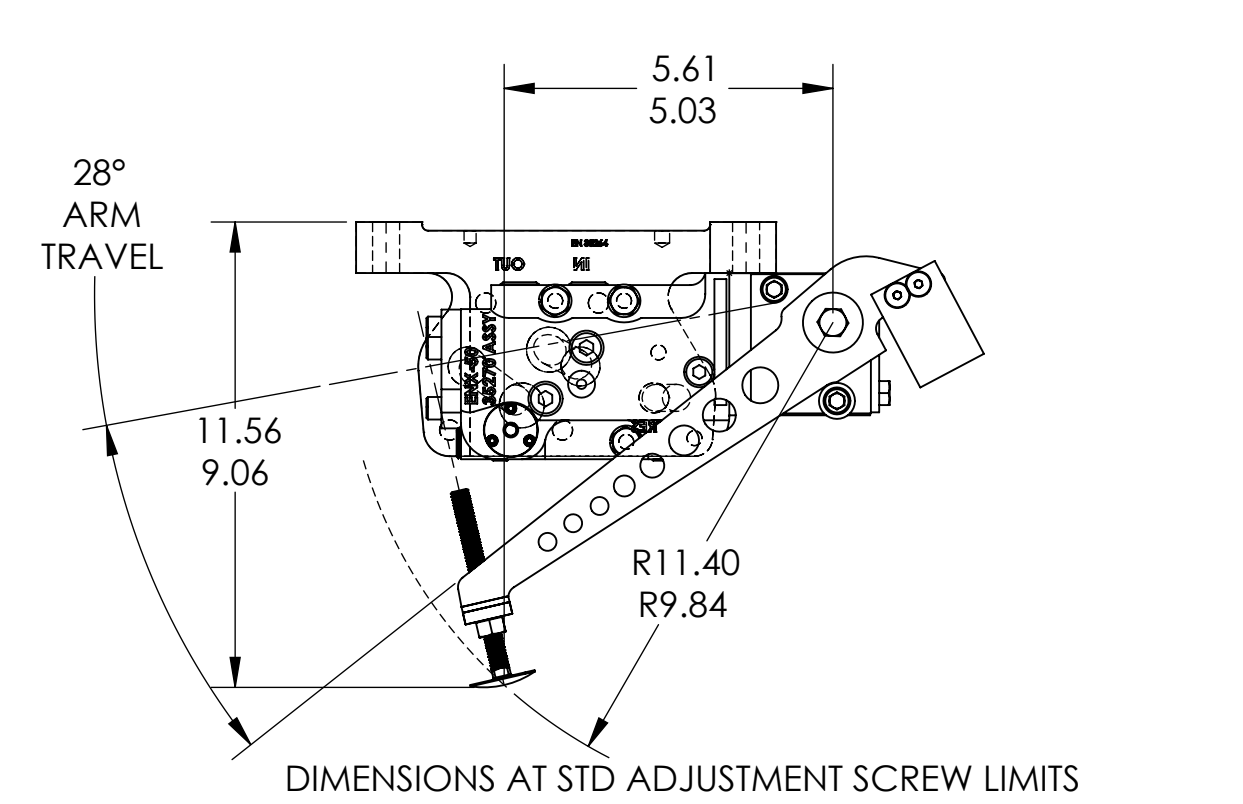
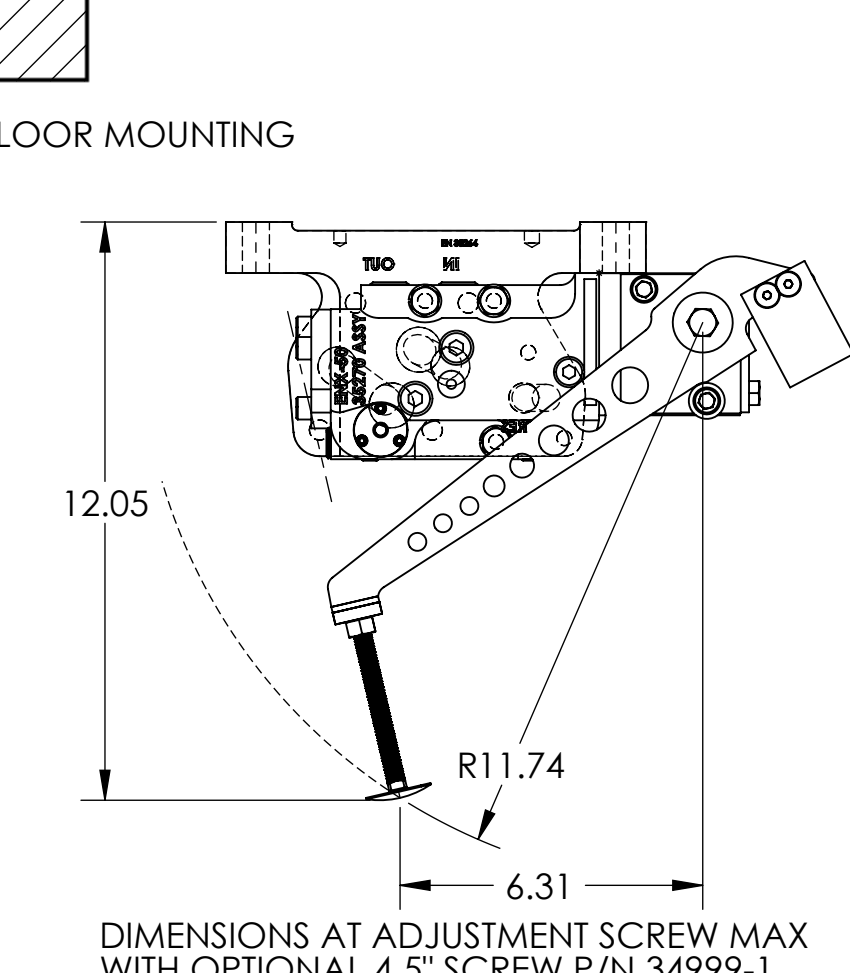
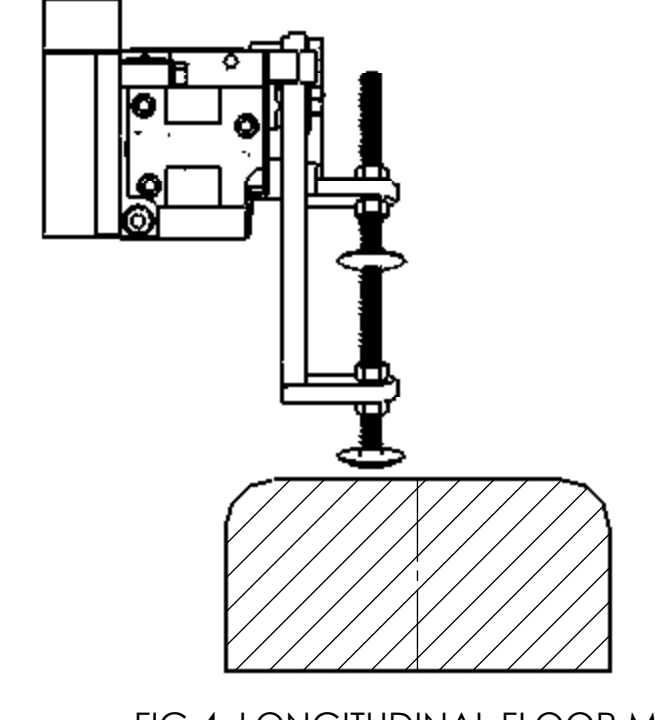
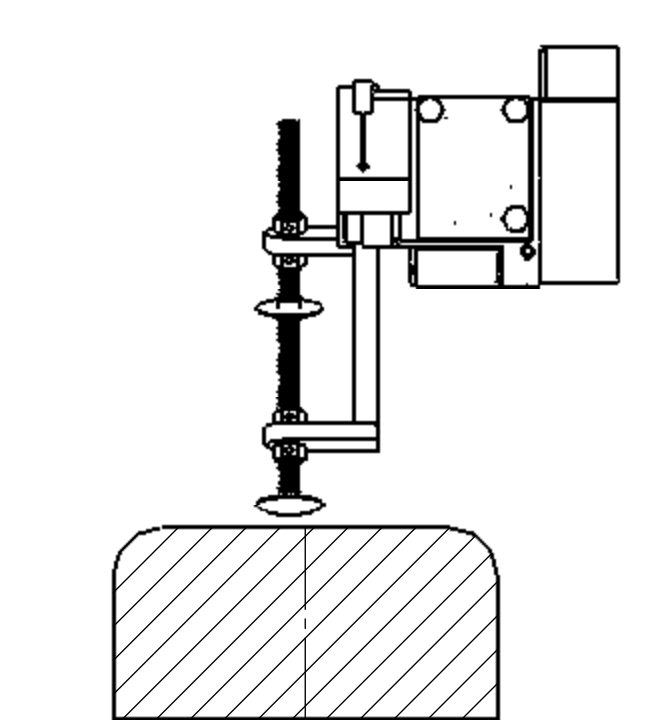
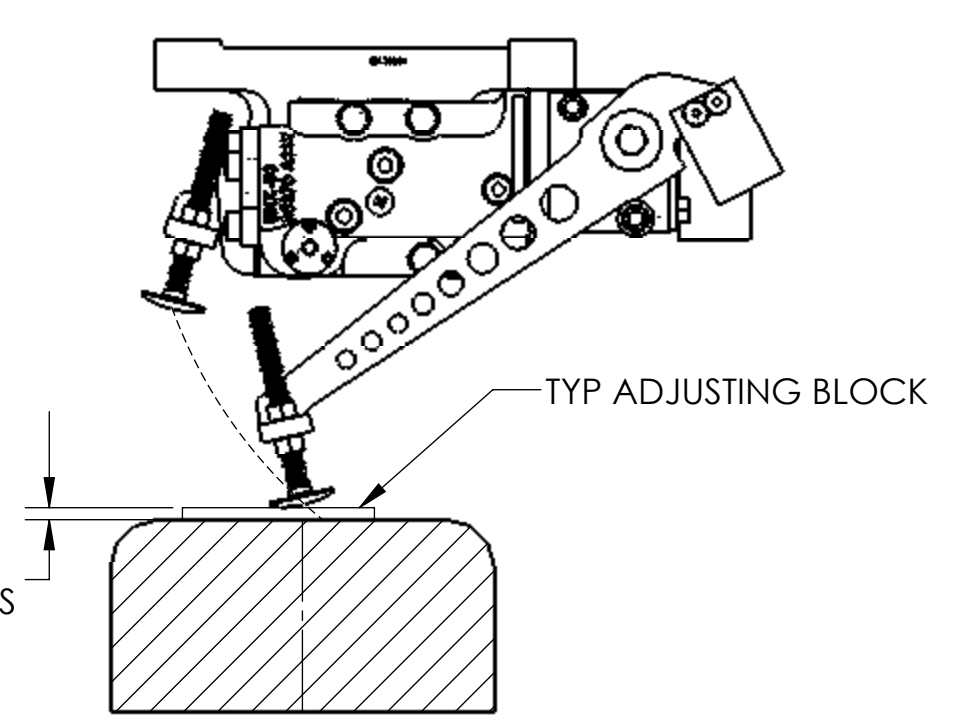
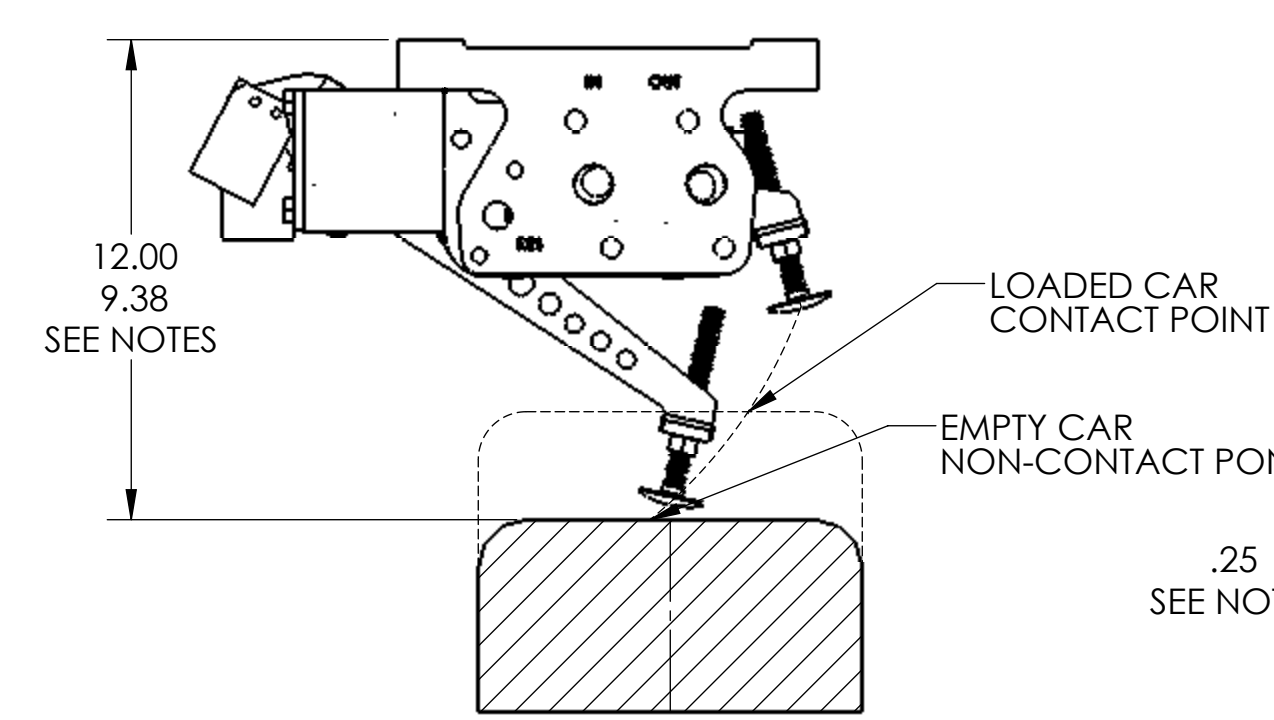
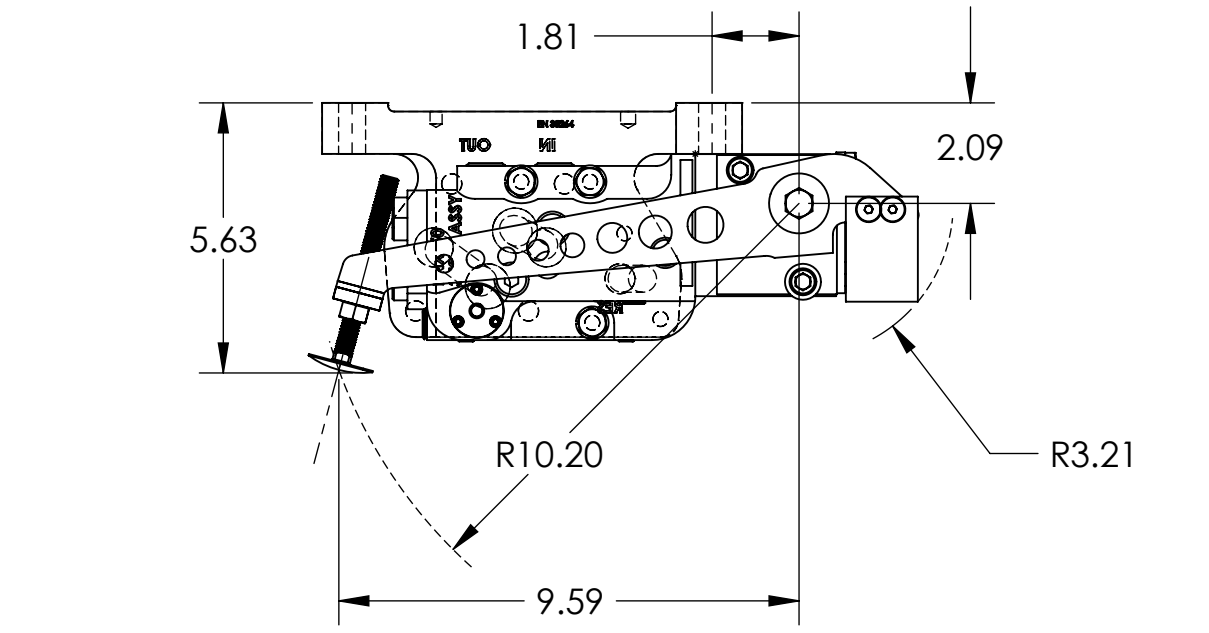
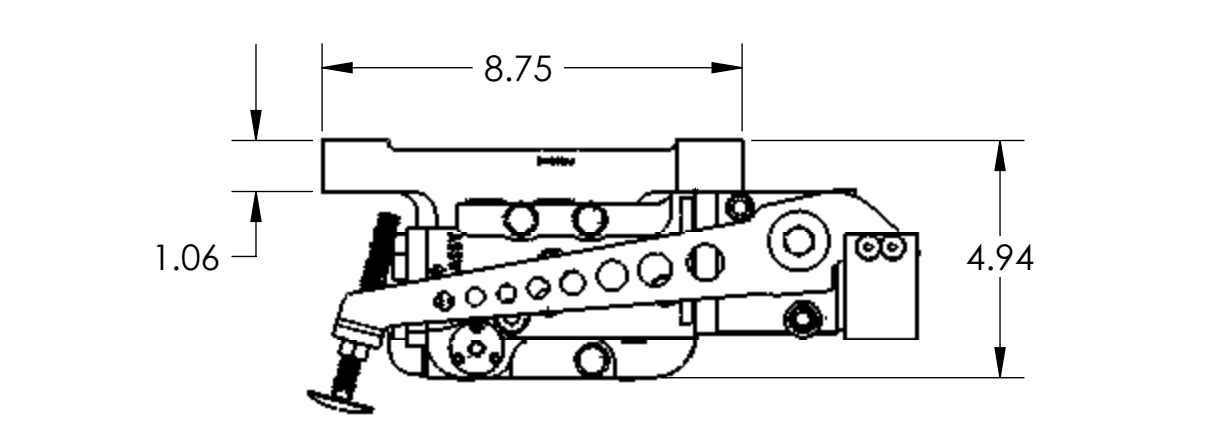
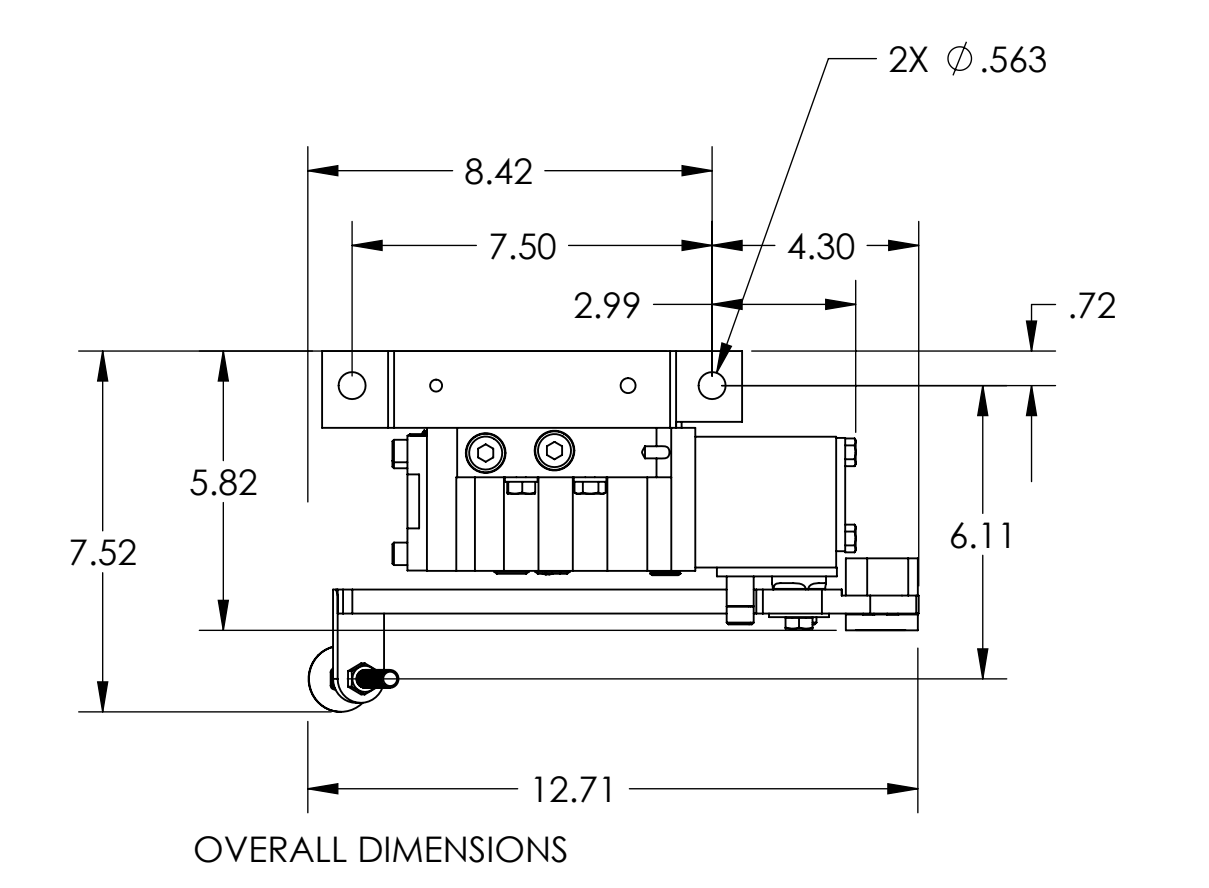
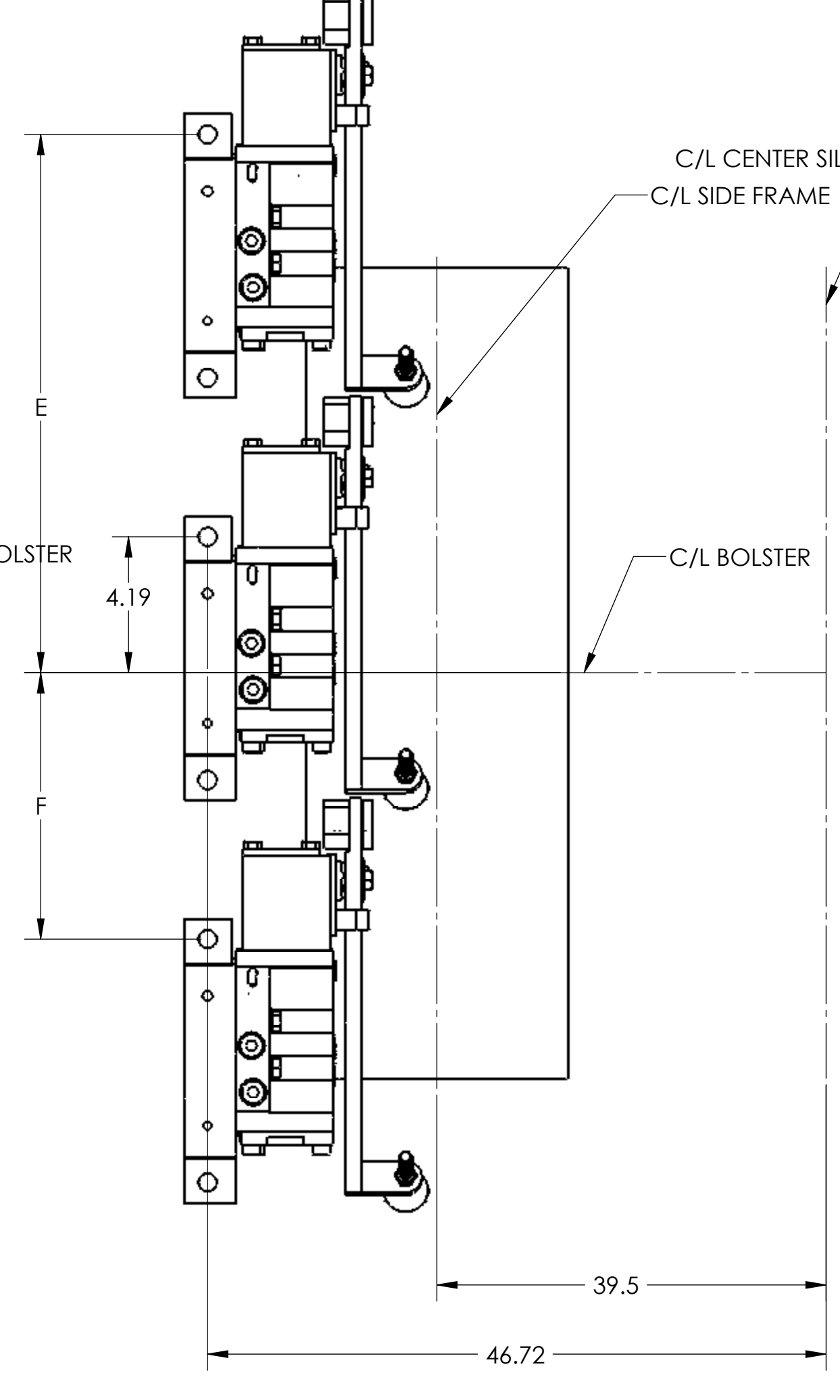
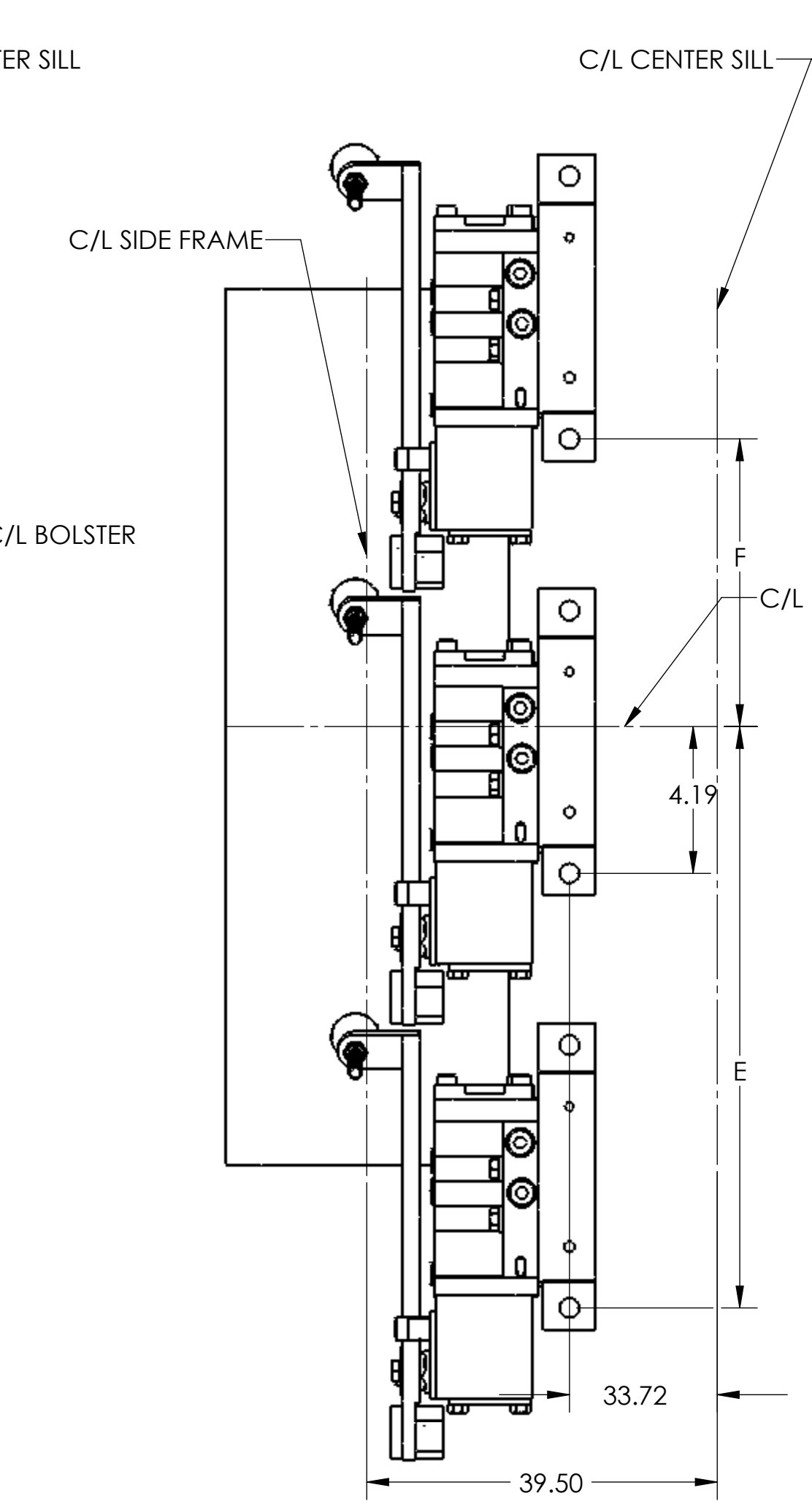
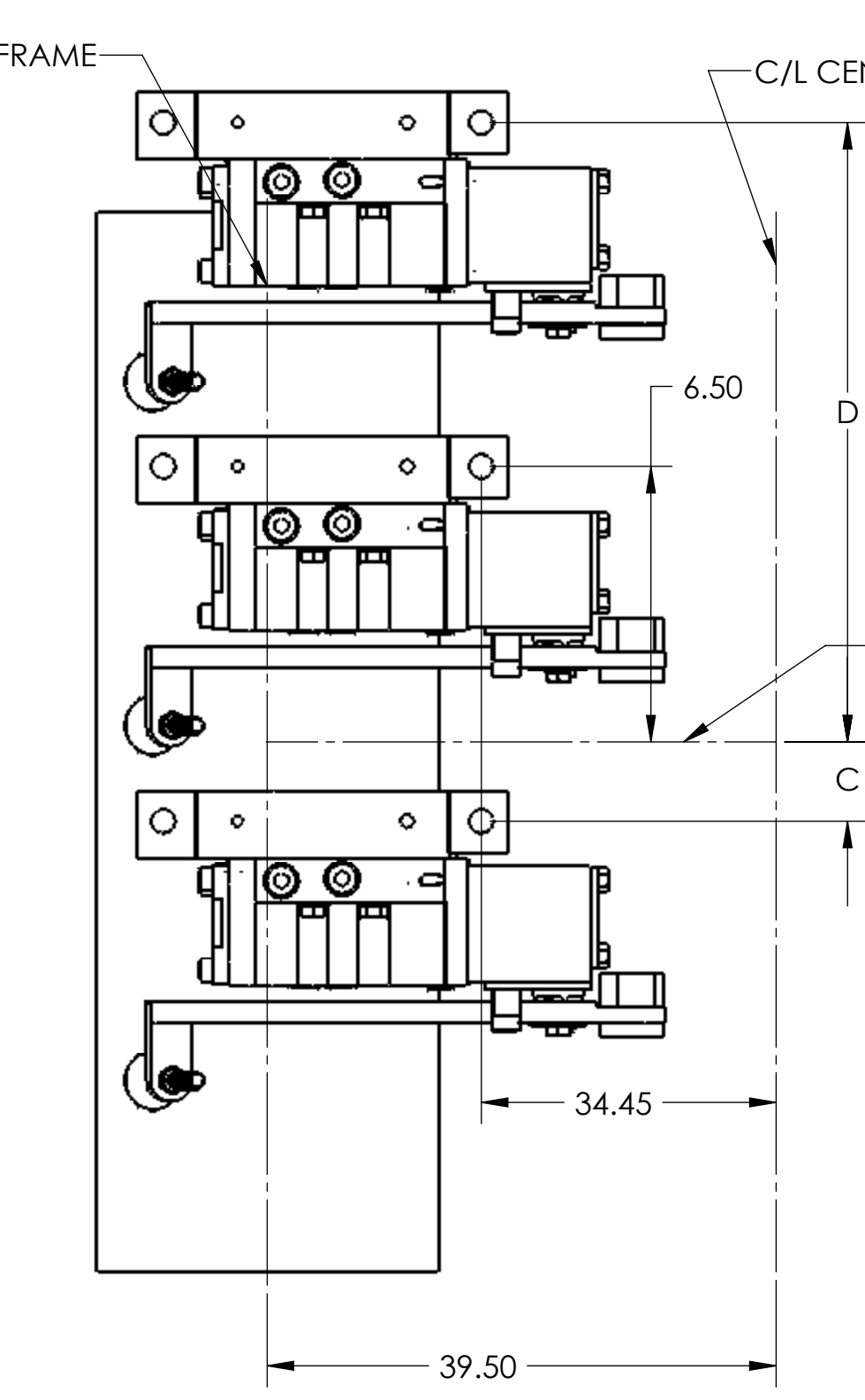
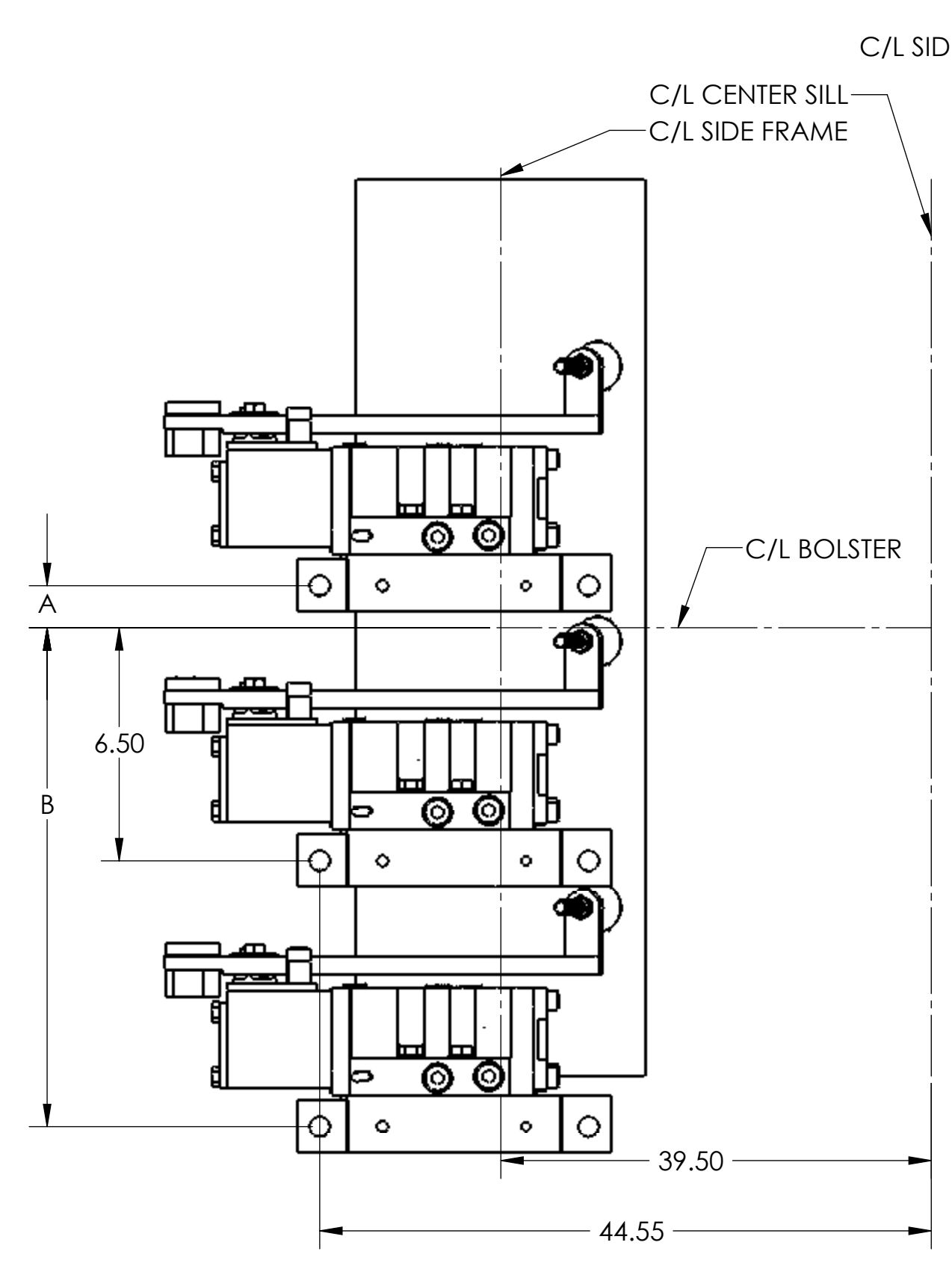

- NEW CAR INSTALLATION AND REQUIREMENTS**
1. THE TOP SURFACE OF THE SIDE FRAME IS TO BE FLAT FOR 12.5 INCHES MINIMUM LENGTH ON EITHER SIDE OF CENTER, PER AAR MANUAL.
 2. SIDE FRAME PARTING LINE FLASH MUST BE GROUND SMOOTH THROUGH THE ENTIRE CONTACT RANGE OF THE ADJUSTING SCREW HEAD, THROUGH THE TRUCK SWING, SPRING DEFLECTION, AND TRUCK COMPONENT WEAR.
 3. TRUCK SWING "CURVE" TEST SHOULD BE PERFORMED TO ASSURE PROPER CONTACT BETWEEN THE ADJUSTING SCREW HEAD AND TRUCK SIDE FRAME.
 4. IF VALVE IS SUBJECT TO DANGER FROM CAR BODY ROLL, A PROTECTIVE BLOCK MUST BE WELDED TO THE CAR STRUCTURE. A DAMAGED VALVE MAY RESULT IN THE LOSS OF BRAKING FORCE ON THE CAR.
 5. EMPTY/LOAD VALVE MUST BE PROTECTED FROM GRIT BLAST MEDIA.
 6. EMPTY CAR INDICATOR, NAME PLATE, AND VENTS MUST BE MASKED PRIOR TO PAINTING. MASKING MUST BE REMOVED BEFORE CAR GOES INTO SERVICE.
 7. NOMINAL SPRING TRAVEL BETWEEN EMPTY AND LOADED CAR IS 2.50 MAX AND 1.88 MIN.
 8. SELECT VALVE MOUNTING TO SUIT CAR CONSTRUCTION AND PIPING. SEE FIGURES 1-4.
 9. MOUNTING HEIGHT (SEE FIGURE 1) SHOULD BE INCREASED FOR LUBRICATION PADS (1/8" RECOMMENDED) PLUS ALLOWANCE FOR NEW CAR SETTLING (1/4" RECOMMENDED). LONG ADJUSTING SCREW REQUIRED FOR MOUNTING HEIGHT OVER 11.5".
- ADJUSTMENT PROCEDURE**
10. ADJUSTMENT MUST BE DONE ON AN EMPTY CAR AND LEVEL TRACK.
 11. DETERMINE ADJUSTING HEIGHT BLOCK THICKNESS FROM NOTE 9. ON REVENUE CARS (CAR HAS SETTLED) USE A 1/4" BLOCK.
 12. WITH BRAKES APPLIED (20 PSI REDUCTION FROM 90 PSI BRAKE PIPE), ADJUST CONTACT SCREW UNTIL THE ADJUSTING BLOCK LIGHTLY DRAGS BETWEEN THE CONTACT SCREW HEAD AND THE TOP OF THE TRUCK SIDE FRAME. LOCK ADJUSTING SCREW IN PLACE. EMPTY CAR INDICATOR SHOULD BE VISIBLE.
 13. RELEASE AIR, CHARGE SYSTEM, PLACE 2" BLOCK UNDER CONTACT SCREW, APPLY BRAKES (20 PSI REDUCTION FROM 90 PSI BRAKE PIPE). EMPTY CAR INDICATOR SHOULD NOT BE EXTENDED, INDICATING LOADED CAR.
 14. TRUCK SWING "CURVE" TEST SHOULD BE PERFORMED (PER AAR REQUIREMENTS) TO ASSURE PROPER CONTACT BETWEEN ADJUSTING SCREW HEAD AND TOP OF SIDE FRAME IN EMPTY CAR AND LOADED CAR SPRING HEIGHTS.

MAXIMUM INSTALLATION MOUNTING DIMENSIONS						
SIDE FRAME IDENTIFICATION	A	B	C	D	E	F
EXAMPLE						
36 DIA. WHEELS, 6 1/2 JOURNALS	1.165	13.915	1.865	14.615	12.09	3.71
12 1/2 FLAT, 7/8 RISE						
AAR MANUAL D-8 1972						
36 DIA. WHEELS, 6 1/2 JOURNALS	0.495	13.245	1.245	13.99	11.42	3.04
12 1/2 FLAT, 1/4 RISE						
AAR MANUAL D-8A 1972						
38 DIA. WHEELS, 6 1/2 JOURNALS	-0.29	12.455	0.90	13.155	10.63	2.26
12 1/2 FLAT, 2/4 RISE						
AAR MANUAL D-8B 1972						
38 DIA. WHEELS, 6 1/2 JOURNALS	-0.54	12.205	0.155	12.905	10.38	2.00
12 1/2 FLAT, 3/4 RISE						

ENX ASY PART NUMBERS - RIGHT HAND LOW PROFILE				
	WITHOUT BCRD TAP		WITH BCRD TAP	
	STD ADJ. SCREW	LONG ADJ. SCREW	STD ADJ. SCREW	LONG ADJ. SCREW
40%	ENX-40R-LP	ENX-40R-LP-S	ENX-40R-LPF	ENX-40R-LPF-S
50%	ENX-50R-LP	ENX-50R-LP-S	ENX-50R-LPF	ENX-50R-LPF-S
60%	ENX-60R-LP	ENX-60R-LP-S	ENX-60R-LPF	ENX-60R-LPF-S

THIS DOCUMENT AND ITS CONTENTS CONTAIN CONFIDENTIAL AND PROPRIETARY INFORMATION OWNED BY ELLCON-NATIONAL, INC. AND IT AND ALL COPIES THEREOF ARE TO BE RETURNED TO ELLCON-NATIONAL WHEN SO REQUESTED. THIS DOCUMENT OR ANY PART THEREOF SHALL NOT BE REPRODUCED, COPIED, OR TRANSMITTED ELECTRONICALLY. THE INFORMATION CONTAINED HEREIN SHALL NOT BE DISCLOSED TO OTHERS OR USED BY RECIPIENT WITHOUT THE PRIOR WRITTEN CONSENT SPECIFIC TO EACH CASE. ELLCON-NATIONAL, INC.

LEGEND
Ø - DIAMETER
Ψ - DEPTH
⊥ - COUNTERBORE
⊥ - COUNTERSINK
— - FLATNESS
— - PARALLELISM
⊥ - PERPENDICULARITY
⊙ - CONCENTRICITY

TOLERANCES AND FINISHES UNLESS OTHERWISE NOTED
 DECIMALS .XX ± 0.030
 DECIMALS .XXX ±
 ANGLES ± °
 FRACTIONS ± 1/32
 DRILLED HOLE DIAMETERS
 BREAK ALL SHARP CORNERS AND EDGES
 CS: ALL TAPPED HOLES 118° ± ONE
 THREAD DEEP
 MACHINED SURFACES

ELLCON NATIONAL
 50 BEECHTREE BLVD. GREENVILLE, S.C. 29605

VALVE ASY INSTALLATION, ENX RIGHT HAND LOW PROFILE

SCALE 1:4 DATE 06/28/2007 REV.
 DRAWN SDM
 CHECKED DWS
D-35331-LP