

REVISIONS			
LTR	DATE	DESCRIPTION	BY
		RELEASED PER EDR 95-520	
A	2-6-97	P/N 5844 WAS P/N 3896 AT A-8, 33mm DIA. DRILL WAS 1 1/8 AT A-9, DIM 7' WAS 7" AT C-7. REDESIGNED JAW PER ECN 172	PL

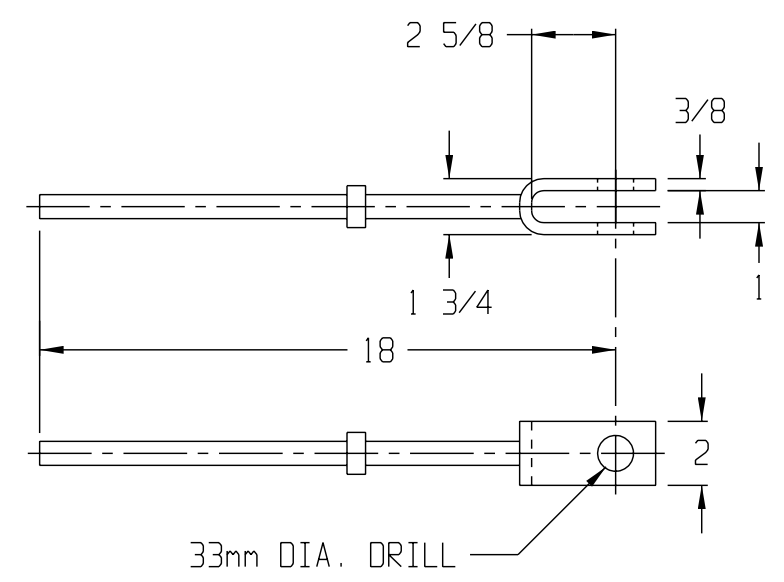
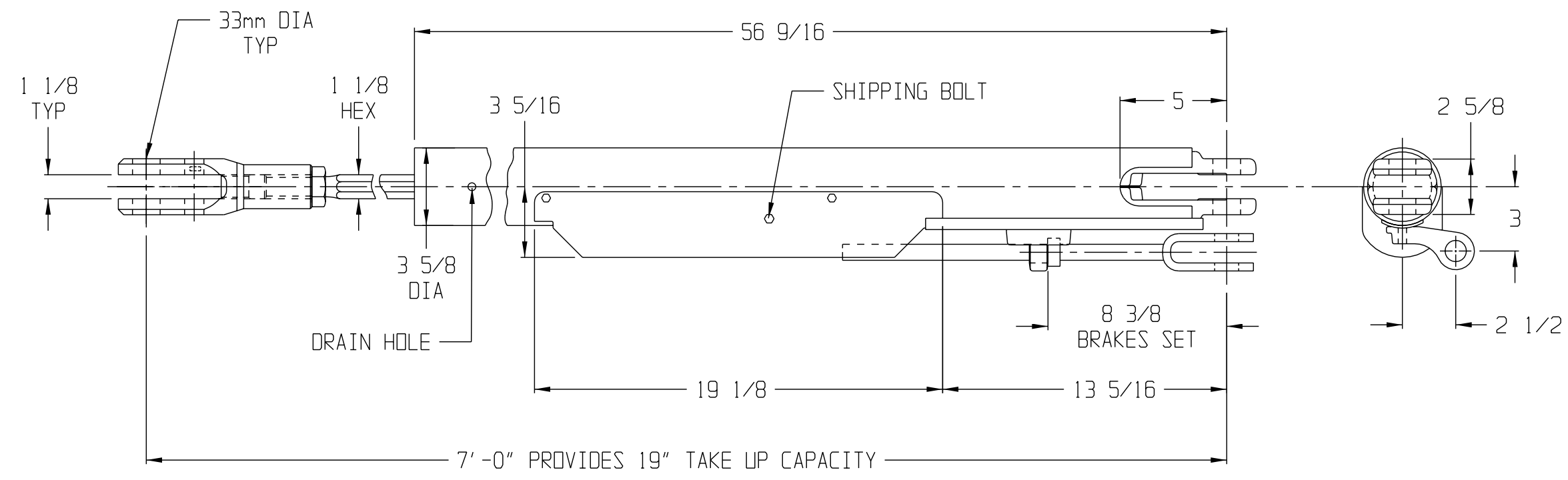

- NOTES-
1. UNITS NORMALLY SHIPPED AT 6'-9" LENGTH WHICH PROVIDES 16" TAKE-UP CAPACITY UNLESS OTHERWISE SPECIFIED
 2. CARBUILDER SHOULD ALLOW A MINIMUM OF 1 INCH CLEARANCE BEYOND DIMENSIONS SHOWN.
 3. AFTER S.A. IS INSTALLED ON CAR, REMOVE PLASTIC PROTECTOR (P/N 4087-8) FROM THE LOWERMOST OF THE 4 DRAIN HOLES

CONTROL ROD ASSEMBLY
P/N 5844

PATENTED

COVERED BY A.A.R.
CERTIFICATE No. 10A

THIS DOCUMENT AND ITS CONTENTS CONTAIN CONFIDENTIAL AND PROPRIETARY INFORMATION OWNED BY ELLCON-NATIONAL, INC. AND IT AND ALL COPIES THEREOF ARE TO BE RETURNED TO ELLCON-NATIONAL WHEN SO REQUESTED. THIS DOCUMENT OR ANY PART THEREOF SHALL NOT BE REPRODUCED, COPIED, OR TRANSMITTED ELECTRONICALLY. THE INFORMATION CONTAINED HEREIN SHALL NOT BE DISCLOSED BY THE RECIPIENT TO OTHERS OR USED BY RECIPIENT WITHOUT THE PRIOR WRITTEN CONSENT SPECIFIC TO EACH CASE. ELLCON-NATIONAL, INC.

	2000-DJSDA
NEXT ASS'Y	USED ON

TOLERANCES AND FINISHES UNLESS OTHERWISE NOTED

DECIMALS .XX ±

DECIMALS .XXX ±

ANGLES ±

FRACTIONS ±

DRILLED HOLE DIAMETERS

BREAK ALL SHARP CORNERS AND EDGES

CHK ALL TAPPED HOLES 118° x ONE THREAD DEEP

MACHINED SURFACES 125/

ELLCON  NATIONAL

50 BEECHTREE BLVD. GREENVILLE, S.C. 29605

OUTLINE DIMENSIONS
MODEL 2000-DJSDA
SLACK ADJUSTER

SCALE 2" = 1'-0"	DATE 9-21-95	REV.
DRAWN PAB	B-33165	A
CHECKED DMS		