

COVERED BY PATENTS  
U.S. 4312428  
CANADA 1163931

REVISIONS			
LTR	DATE	DESCRIPTION	BY
		ISSUED PER EDR 96-340	
A	4/18/97	DIM: 2 1/16 WAS 2 9/16. 1 11/16 WAS 2 3/8 P/N 32361-20 WAS 32361-22. PER EDR # 298.	PS
B	11-25-97	P/N 33158 WAS 3443-33. 34025 WAS 33716. PER EDR # 791	RES
C	3-3-99	ADDED: NOTE 15, & IT. 33. IT. 9 WAS QTY 10. CHANGED AIR BRAKE FORCES WERE BASED ON 50 PSI. PER EDR #1903	PS

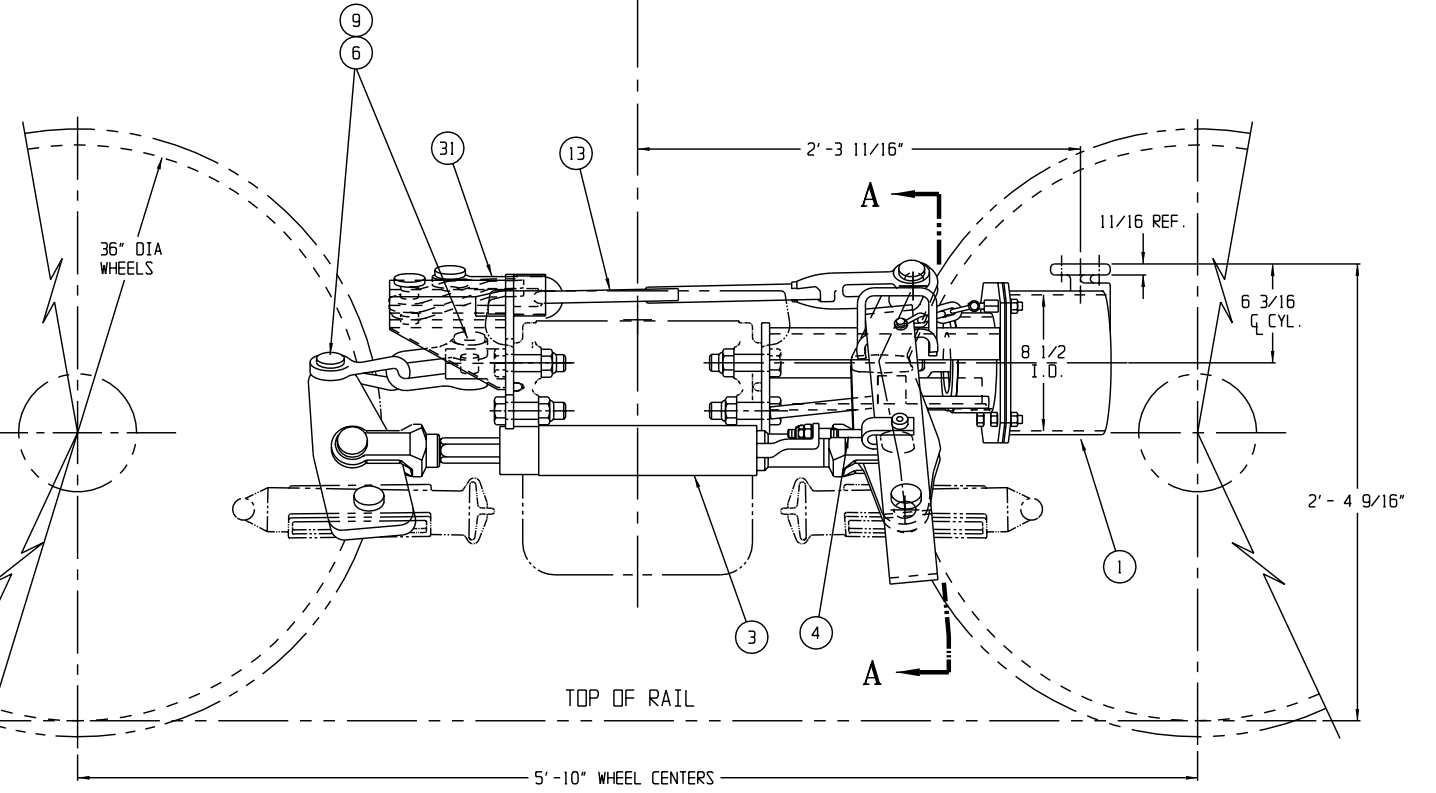
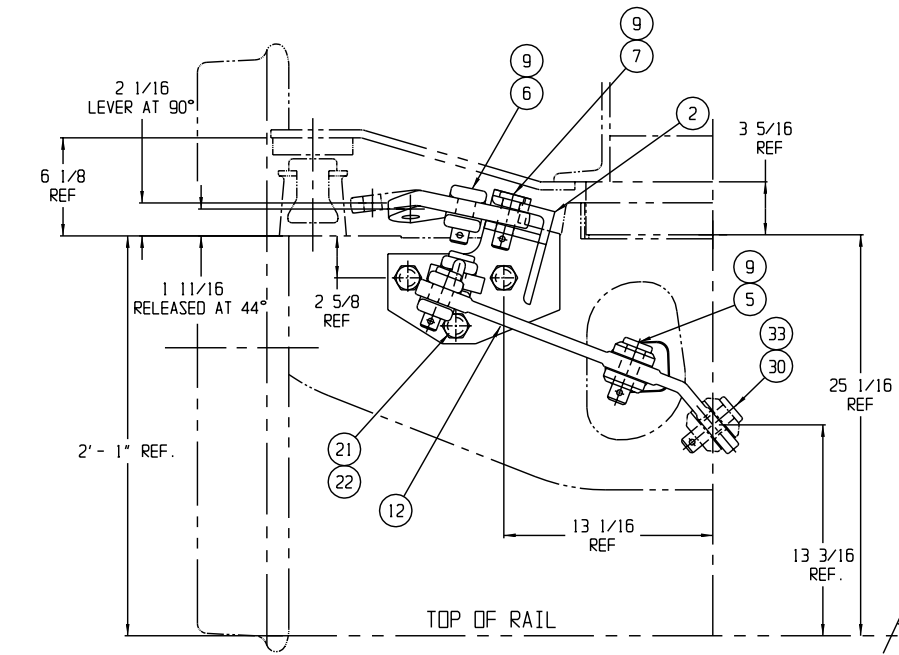
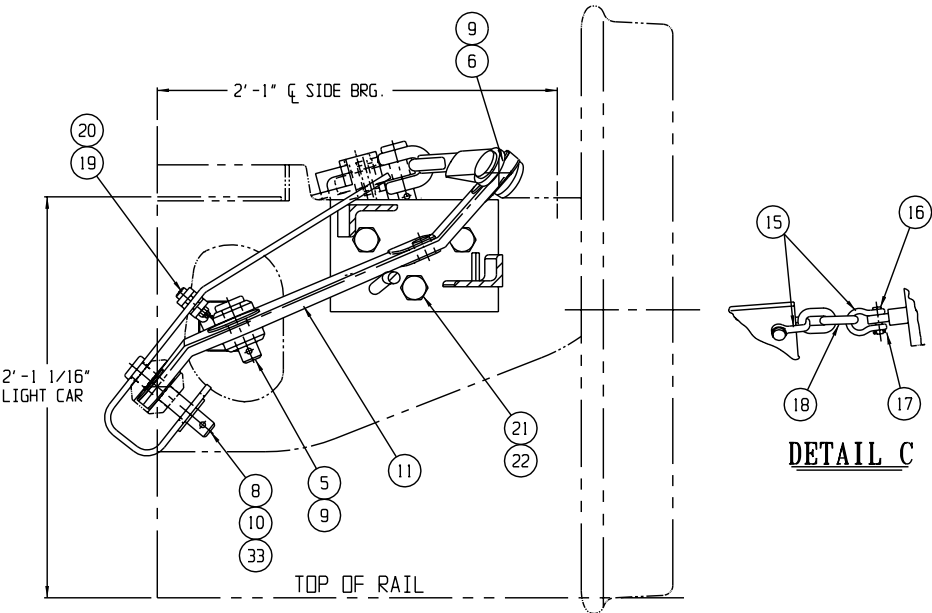
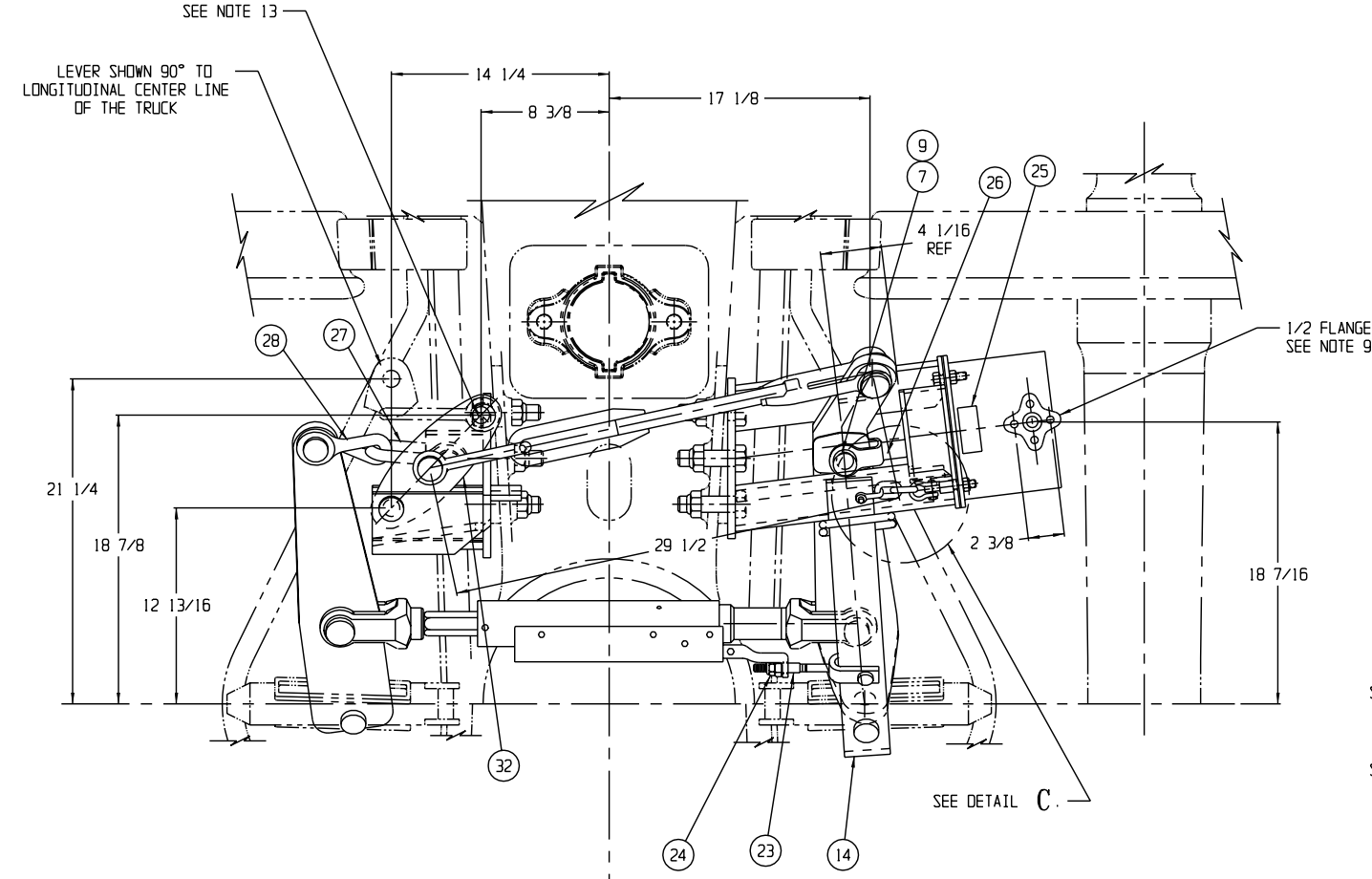
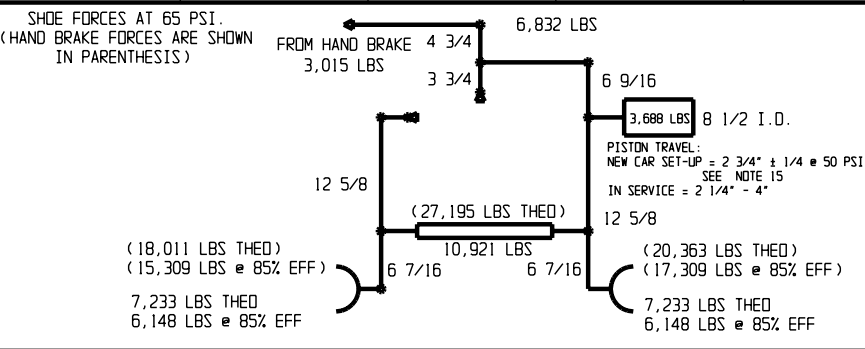

- NOTES:
- SEE PURCHASE ORDER FOR DRAWING NO. SHOWING TRUCK MOUNTED BRAKE AND LEVER LOCATIONS.
  - QUANTITIES SHOWN ARE FOR ONE TRUCK-SET OF MATERIAL.
  - THIS TRUCK MOUNTED BRAKE IS DESIGNED FOR USE WITH NO. 24 BRAKE BEAMS. WHEN USING ANY OTHER BRAKE BEAMS CONTACT ELLCON NATIONAL.
  - BADGE PLATE WILL BE SUPPLIED BY CARBUILDER.
  - THESE PARTS TO BE SHIPPED AS AN ASSEMBLY P/N 31550.
  - TRUCK MOUNTED BRAKE IS SHOWN IN LIGHT CAR, BRAKE RELEASED, AT HAND BRAKE TRUCK WITH LIVE LEVER NO. 9548-1624.
  - DO NOT LIFT USING ANY PART OF THE TRUCK MOUNTED BRAKE.
  - TORQUE NUTS (ITEM 22) TO 250-300 FT. LBS.
  - FOR AIR BRAKE CONNECTION THE CARBUILDER WILL USE (2) 1/2-13 UNC SELF LOCKING BOLTS.
  - THERE SHOULD BE SLACK ALLOWED IN HORIZONTAL CHAIN CONNECTION FOR A CAR TO NEGOTIATE A 180 FT. OR 150 FT. RADIUS CURVE FOR A.A.R. SPECIFICATION.
  - THE (2) PISTON TRAVEL INDICATOR DECALS ITEM 29 (P/N 32804) HAVE TO BE APPLIED BY THE CAR BUILDER TO EACH SIDE OF THE CAR IN THE CYLINDER AREA. THE DECALS ARE SHIPPED LOOSE.
  - UNLESS OTHERWISE NOTED, ALL DIMENSIONS ARE NOMINAL.
  - 6\"/>

	2	9008-3	COTTER PIN, WEDGE FAST, 5/16 X 3	33
SEE NOTE 14---	A/R	32361-20	MULTIPLYING LEVER (8 1/2 X 3 3/4)	32
	1	32315	CLEVIS	31
	1	30538-1	CLEVIS PIN, 1 11/32 X 3 TO $\phi$ HOLE	30
SEE NOTE 11---	2	32804	P.T INDICATOR DECAL	29
	1	31411	CLEVIS (90 R.H. TWIST)	28
	1	8819	CLEVIS	27
	1	9280	PUSH ROD (PART OF ITEM 1)	26
	1	30252	NAMEPLATE (PART OF ITEM 1)	25
	1	4493-35	NUT (ESNA), 1/2-13 (PART OF ITEM 3)	24
	1	33158	CONTROL ARM NUT 1/2-13 (PART OF ITEM 3)	23
	6	4493-31	NUT (ESNA), 1-8	22
	6	3442-137	BOLT, 1-8 UNC X 3 3/4 LG. (GR5)	21
	1	5340-4	SHOULDER BOLT, 3/8-16	20
	1	4493-8	NUT (ESNA), 3/8-16	19
	1	31439	CHAIN	18
SEE NOTE 5	2	31438-3	COTTER PIN	17
	2	31438-2	PIN	16
	2	31438-1	SHACKLE	15
	1	31157	ACTUATOR LEVER	14
	1	33715-1	PULL ROD	13
SEE NOTE 1	A/R	9578-1124	DEAD LEVER	12
	A/R	9548-1624	LIVE LEVER (HAND BRAKE TRUCK)	11
	1	3958-35	WASHER, PLAIN, 1 3/8	10
	8	9008-2	COTTER PIN, WEDGE FAST, 5/16 X 2 1/2	9
	1	30538-2	CLEVIS PIN, 1 11/32 X 5 3/8 TO $\phi$ HOLE	8
	2	30166-2	CLEVIS PIN, 1 3/32 X 2 1/2 TO $\phi$ HOLE	7
	4	30166-1	CLEVIS PIN, 1 3/32 X 3 TO $\phi$ HOLE	6
	2	30167-1	CLEVIS PIN, 1 7/32 X 3 TO $\phi$ HOLE	5
	1	31139	CONTROL ARM (PART OF ITEM 3)	4
	1	7100-26	SLACK ADJUSTER (DOUBLE ACTING)	3
	1	34025	DEAD LEVER BRACKET	2
	1	30995-1	BOLSTER SADDLE AND CYLINDER ASS'Y.	1

QTY.	PART NO.	DESCRIPTION	ITEM
BILL OF MATERIAL			
100 TON APPLICATION MODEL 8500 TRUCK MOUNTED BRAKE			
MATERIAL:	WEIGHT: 257 LBS PER TMB WITH HANDBRAKE LEVER (LESS BRAKE BEAMS, SHOES, KEYS AND CYLINDER HOSE)	SCALE 2"=1'-0"	DATE 7-1-96
DRAWN PRM	CHECKED PS	TMB-681-LC	REV.

THIS DOCUMENT AND ITS CONTENTS CONTAIN CONFIDENTIAL AND PROPRIETARY INFORMATION OWNED BY ELLCON-NATIONAL, INC. AND IT AND ALL COPIES THEREOF ARE TO BE RETURNED TO ELLCON-NATIONAL WHEN SO REQUESTED. THIS DOCUMENT OR ANY PART THEREOF SHALL NOT BE REPRODUCED, COPIED, OR TRANSMITTED ELECTRONICALLY. THE INFORMATION CONTAINED HEREIN SHALL NOT BE DISCLOSED BY THE RECIPIENT TO OTHERS OR USED BY RECIPIENT WITHOUT THE PRIOR WRITTEN CONSENT SPECIFIC TO EACH CASE. ELLCON-NATIONAL, INC.