

COVERED BY PATENTS
U.S. 4312428
CANADA 1163931

REVISIONS			
LTR	DATE	DESCRIPTION	BY
C	4-7-98	REDRAWN ON CAD WITH THE FOLLOWING CHANGES: ADDED NOTES & RENUMBERED EXISTING NOTES ADDED: NOTE IN SCHW DNG, 82% EFF LBS IN SCHW DNG, DIM 2'-1 3/4" @ E-9, DIM 7 1/4" @ H-14, DIM 14 1/2" @ K-13, ITEMS 30 & 31. "SEE NOTE 5" @ J-17. PISTON TRAVEL WAS 3" @ B-14. DETAIL C WAS VEIN 9-B. ITEM 23 WAS P/N 3443-33, FOLLOWING DIMS CHANGED: 2'-1" LIGHT CAR WAS 2'-1 5/8" @ E-5/6, 2'-1 9/16" WAS 2'-1 5/16" @ J-10, 21 5/8" WAS 21 1/8" @ K-7, 2'-3 5/16" WAS 2'-2 13/16" @ E-17, 6 3/16 WAS 6 1/4" @ F-17, 11/16 REF WAS 3/4" @ F-16, 2'-3 1/16" WAS 2'-3 3/4" @ G-14, 18 1/16" WAS 18 3/8" @ J-17, 19 3/16" WAS 19 1/8" @ B-15 PER ECN #1232	AKH
D	12-9-98	ADDED IT 32, IT 9 WAS QTY 7, CHANGED IT 9 WITH IT 32 IN TWO PLACES WITH IT 9 & 27. FORCE DIAGRAM WAS CALCULATED BASED ON 50 PSI. PER ECN #1226	JT
E	12-31-98	ADDED NOTE 14, ADDED "50 PSI" AND "SEE NOTE 14" @ B-14. CHANGE PICTURE OF ITEM 1, 17 13/16" WAS 18" @ L-14, 18 7/16" WAS 18 1/16" @ J-17. PER ECN #1753	AKH
F	6-1-00	DELETED ITEM 32 (P/N 9008-3). ITEM 9 WAS 5 REQ'D. P/N 4034-18 WAS 9008-2. ASSEMBLY WAS APPLICATION IN THE TITLE BLOCK. PER ECN #2793	JMB
G	8-1-00	ADDED ITEM 32 (P/N 3442-190). ITEM 21 WAS 5 REQ'D. PER ECN #2883	PS
H	10-10-05	ADDED NOTE 15 AND "SEE NOTE 15" @ J6 PER ECN #6546	BMP

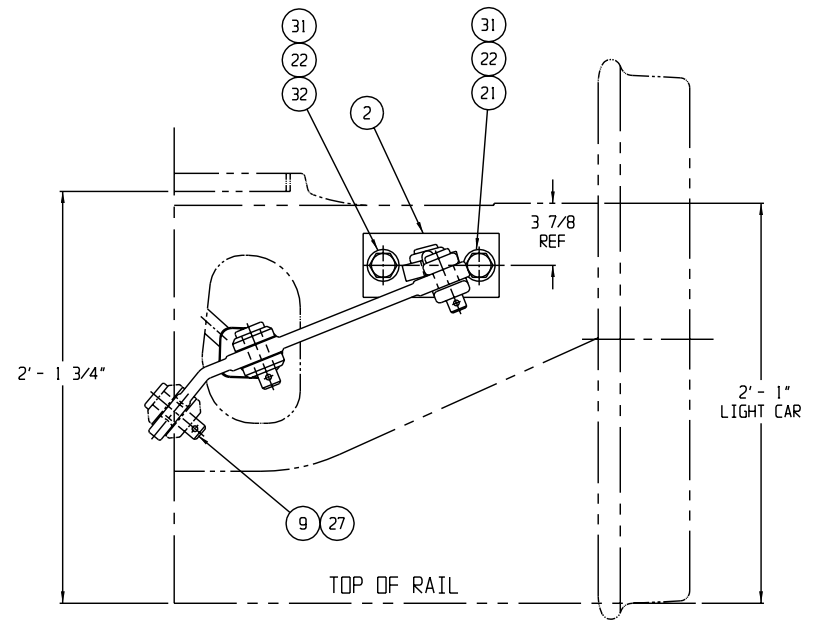
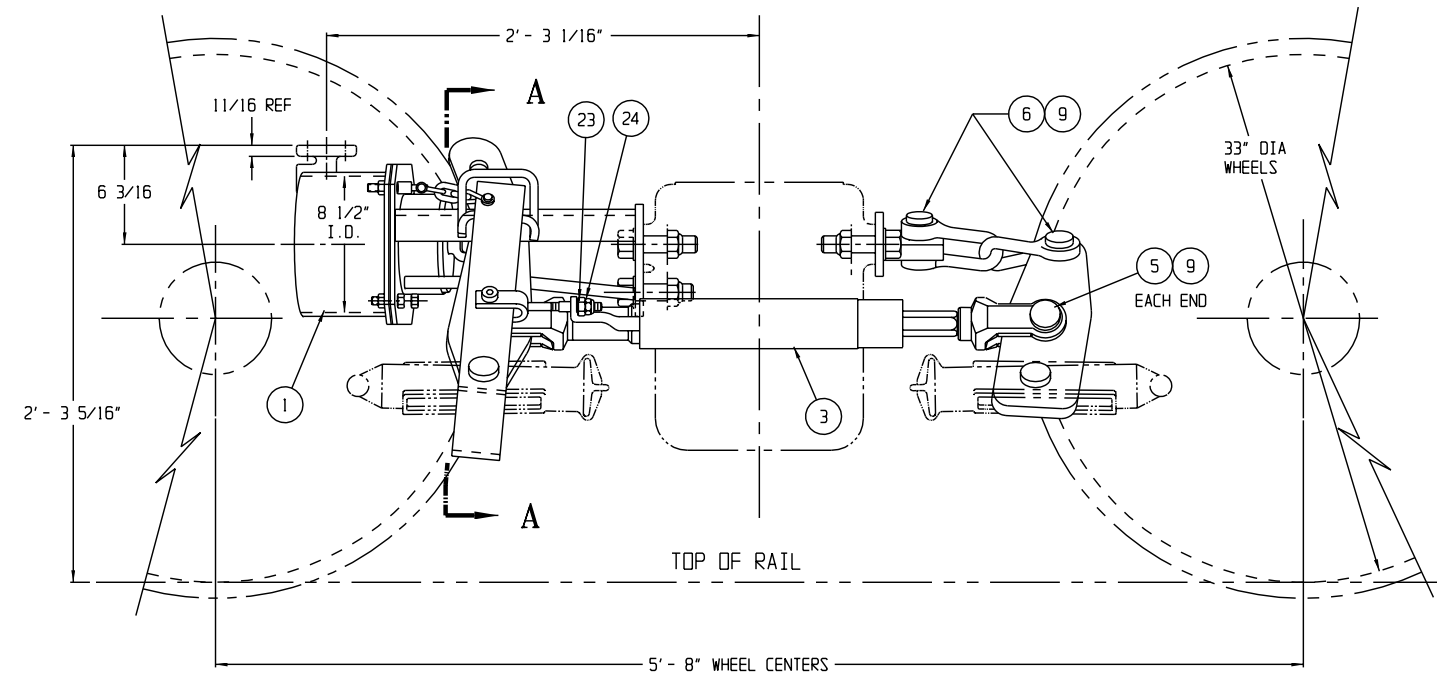
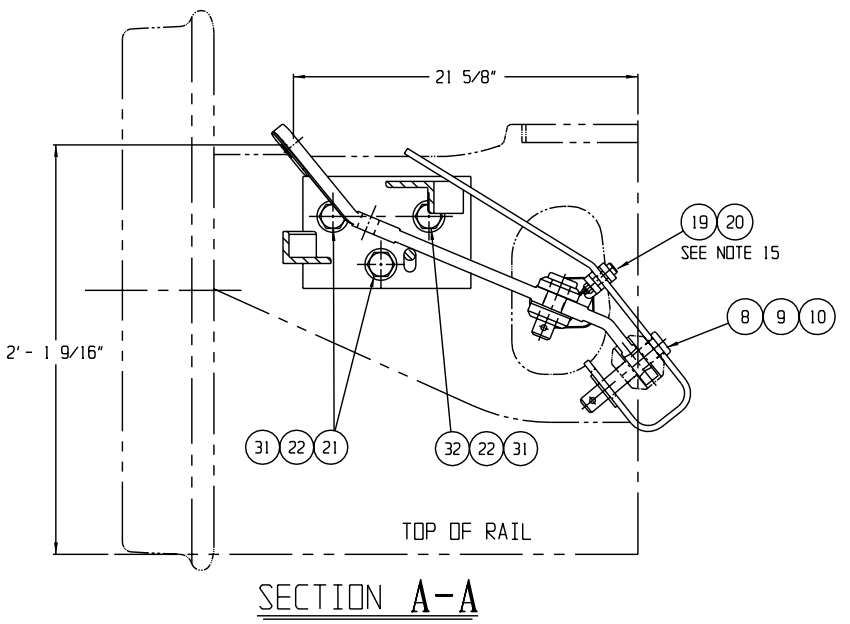
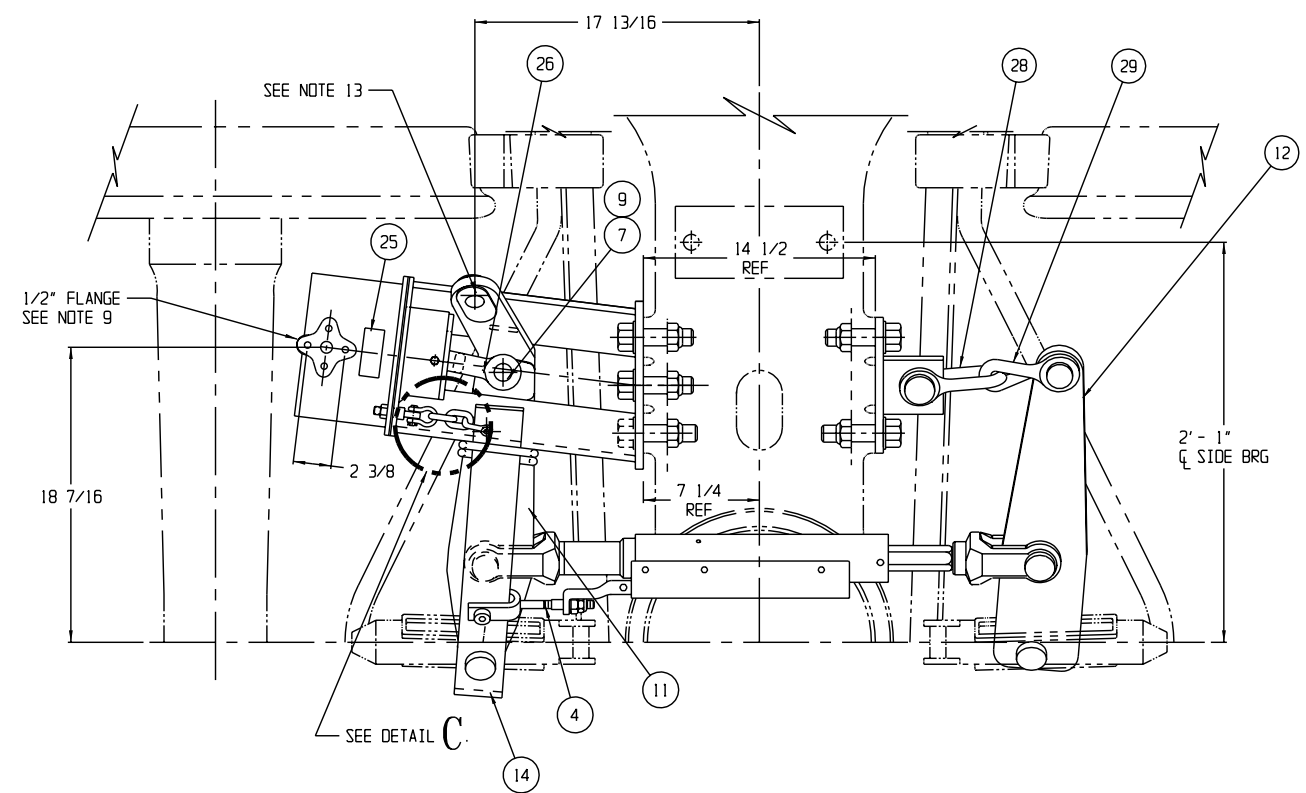

- NOTE:
- SEE PURCHASE ORDER FOR DRAWING NO. SHOWING TRUCK MOUNTED BRAKE AND LEVER LOCATIONS.
 - QUANTITIES SHOWN ARE FOR TRUCK SET OF MATERIAL.
 - THIS TRUCK MOUNTED BRAKE IS DESIGNED FOR USE WITH NO. 24 BRAKE BEAMS. WHEN USING ANY OTHER BRAKE BEAMS CONTACT ELLCON NATIONAL.
 - BADGE PLATES WILL BE SUPPLIED BY CARBUILDER.
 - THESE PARTS TO BE SHIPPED AS AN ASSEMBLY P/N 31550.
 - TRUCK MOUNTED BRAKE IS SHOWN IN LIGHT CAR, BRAKE RELEASED, AT HAND BRAKE TRUCK WITH LIVE LEVER NO. 9548-2624.
 - DO NOT LIFT USING ANY PART OF THE TRUCK MOUNTED BRAKE.
 - TORQUE NUTS (ITEM 22) TO 250-300 FT. LBS.
 - FOR AIR BRAKE CONNECTION THE CARBUILDER WILL USE (2) 1/2-13 UNC SELF LOCKING BOLTS.
 - THERE SHOULD BE SLACK ALLOWED IN HORIZONTAL CHAIN CONNECTION FOR A CAR TO NEGOTIATE A 180 FT. OR 150 FT. RADIUS CURVE FOR A.A.R. SPECIFICATION.
 - THE (2) PISTON TRAVEL INDICATOR DECALS ITEM 30 (P/N 32804) HAVE TO BE APPLIED BY THE CAR BUILDER TO EACH SIDE OF THE CAR IN THE CYLINDER AREA. THE DECALS ARE SHIPPED LOOSE.
 - UNLESS OTHERWISE NOTED, ALL DIMENSIONS ARE NOMINAL.
 - CLEVIS, CLEVIS PIN AND COTTER PIN FOR HAND BRAKE CONNECTION WILL BE SUPPLIED BY THE CAR BUILDER.
 - SEE ELLCON NATIONALS INSTALLATION AND FIELD SERVICE INSTRUCTIONS FOR SET-UP PROCEDURE.
 - SHOULDER BOLT, ITEM 20, CAN BE ASSEMBLED FROM TOP AS SHOWN OR FROM THE BOTTOM WITH NUT, ITEM 19, AT TOP.

QTY.	PART NO.	DESCRIPTION	ITEM
2	3442-190	BOLT, 1-8 UNC X 4.0 LG (GR.5)"GREEN"	32
5	3958-48	WASHER, PLAIN HARDENED 1"	31
2	32804	P.T. INDICATOR DECAL	30
1	31411	CLEVIS (90° R.H. TWIST)	29
1	8819	CLEVIS	28
1	30538-1	CLEVIS PIN 1 11/32 DIA X 3 TO Q HOLE	27
1	9894	PUSH ROD (PART OF ITEM 1)	26
1	30252	NAMEPLATE (PART OF ITEM 1)	25
1	31076-1	LOCKNUT, STOVER, 1/2-13 (PART OF ITEM 3)	24
1	33158	CONTROL ARM NUT, 1/2-13 (PART OF IT 3)	23
5	31076-3	LOCKNUT, STOVER, 1-8	22
3	3442-137	BOLT, 1-8 UNC X 3 3/4 LG (GR.5)	21
1	5340-4	SHOULDER BOLT, 3/8-16	20
1	31076-4	LOCKNUT, STOVER, 3/8-16	19
1	31439	CHAIN	18
2	31438-3	COTTER PIN	17
2	31438-2	PIN	16
2	31438-1	SHACKLE	15
1	31157-1	ACTUATOR LEVER	14
A/R	9547-4124	LIVE LEVER (NON HAND BRAKE TRUCK)	13
A/R	9578-2124	DEAD LEVER	12
A/R	9548-2624	LIVE LEVER (HAND BRAKE TRUCK)	11
1	3958-35	WASHER, PLAIN, 1 3/8	10
7	4034-18	COTTER PIN, 3/8" DIA. X 2 1/2" LG.	9
1	30538-2	CLEVIS PIN, 1 11/32 X 5 3/8 TO Q HOLE	8
1	30166-2	CLEVIS PIN, 1 3/32 X 2 1/2 TO Q HOLE	7
2	30166-1	CLEVIS PIN, 1 3/32 X 3 TO Q HOLE	6
2	30167-1	CLEVIS PIN, 1 7/32 X 3 TO Q HOLE	5
1	31139	CONTROL ARM (PART OF ITEM 3)	4
1	7100-26RS	SLACK ADJUSTER (DOUBLE ACTING)	3
1	30985-2	DEAD LEVER BRACKET	2
1	31805-2	BOLSTER SADDLE AND CYLINDER ASS'Y	1

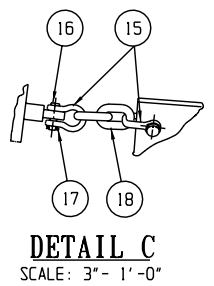
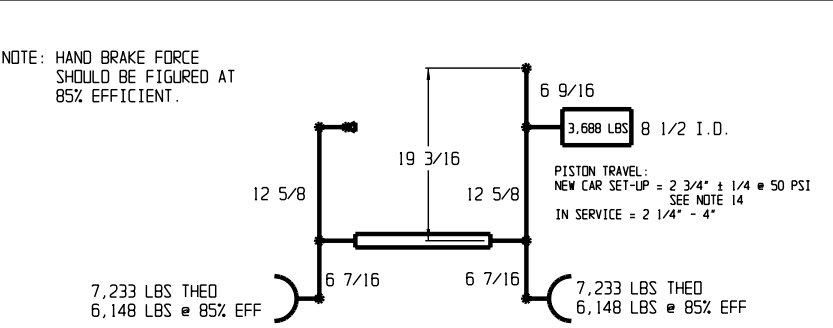

THIS DOCUMENT AND ITS CONTENTS CONTAIN CONFIDENTIAL AND PROPRIETARY INFORMATION OWNED BY ELLCON-NATIONAL, INC. AND IT AND ALL COPIES THEREOF ARE TO BE RETURNED TO ELLCON-NATIONAL WHEN SO REQUESTED. THIS DOCUMENT OR ANY PART THEREOF SHALL NOT BE REPRODUCED, COPIED, OR TRANSMITTED ELECTRONICALLY. THE INFORMATION CONTAINED HEREIN SHALL NOT BE DISCLOSED BY THE RECIPIENT TO OTHERS OR USED BY RECIPIENT WITHOUT THE PRIOR WRITTEN CONSENT SPECIFIC TO EACH CASE. ELLCON-NATIONAL, INC.

MATERIAL: 218 LBS PER TMB WITH HANDBRAKE LEVER (LESS BRAKE BEAMS, SHOES, KEYS AND CYLINDER HOSE)

SCALE	DATE	REV.
2" = 1'-0"	2-11-91	

DRAWN DC
CHECKED DMS

TMB-291-R H

BILL OF MATERIAL

ELLCON NATIONAL
50 BEECHTREE BLVD. GREENVILLE, S.C. 29605

70 TON ASSEMBLY
MODEL 8500
TRUCK MOUNTED BRAKE