

THIS ARRANGEMENT COVERED BY THE FOLLOWING PATENTS
 U.S. 4,500,230
 CANADA 1,192,788

REVISIONS			
LTR	DATE	DESCRIPTION	BY
A	8/14/03	ISSUED PER ECN #5031 DELETED P/N: 30651, 30654 & 30657. P/N 32165 WAS 30656, P/N 31479 WAS 30489 & P/N 31465 WAS 30487. PER ECN #5065	PS

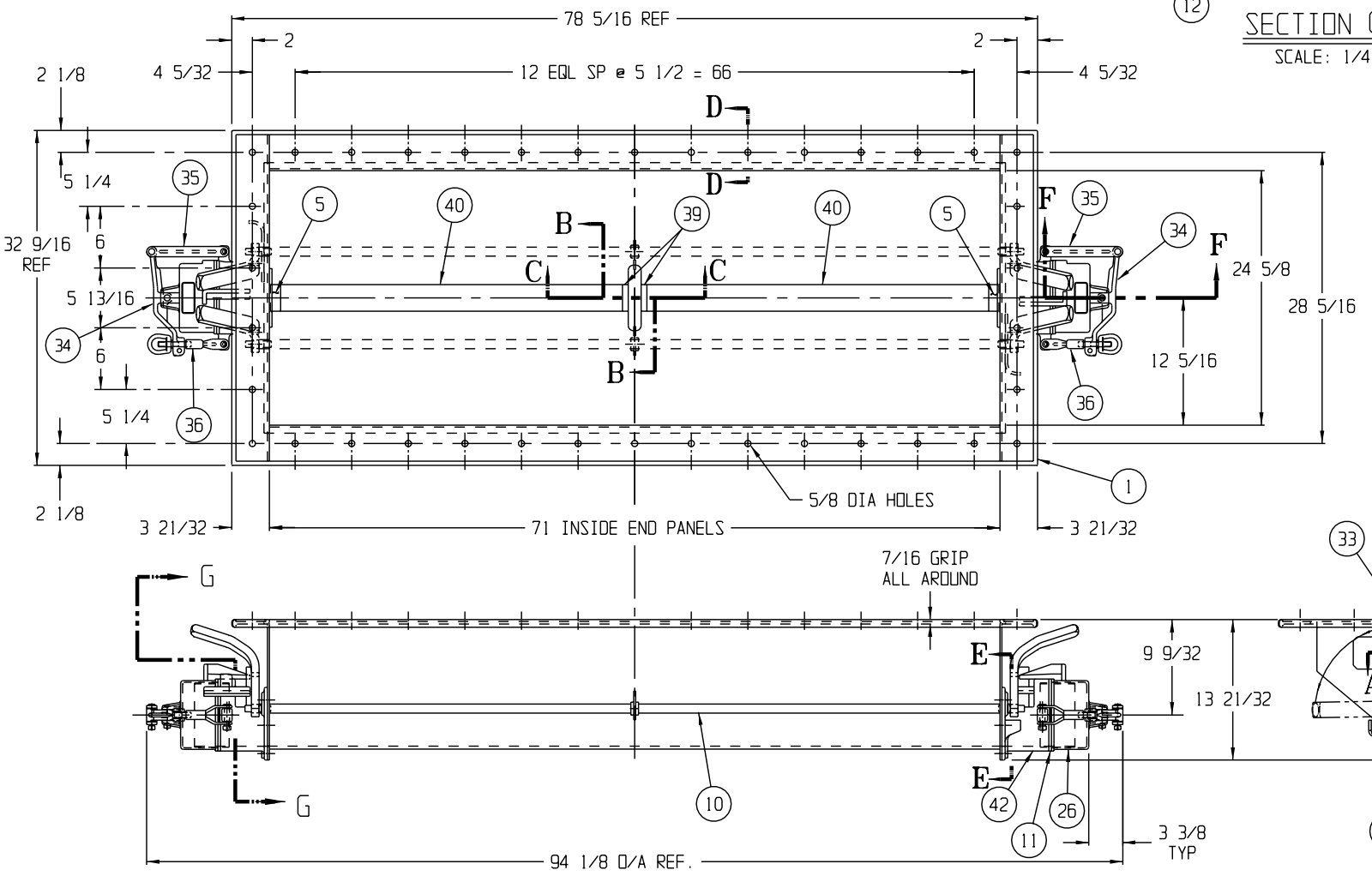

NOTES:
 1-FOR GASKET AND MOUNTING HARDWARE CUSTOMER MUST SPECIFY AS SEPARATE ITEM OR ITEMS ON ORDER WHEN REQUIRED.
 2-INTERIOR OF GATE TO BE FREE OF DIRT, GREASE, BURRS, WELD SPATTER OR ANY OTHER FOREIGN MATTER.
 3-UNLESS OTHERWISE NOTED, ALL DIMENSIONS ARE NOMINAL
 4-TORQUE ITEM 47, TO 84 INCH LBS ±10% (4 PLACES)

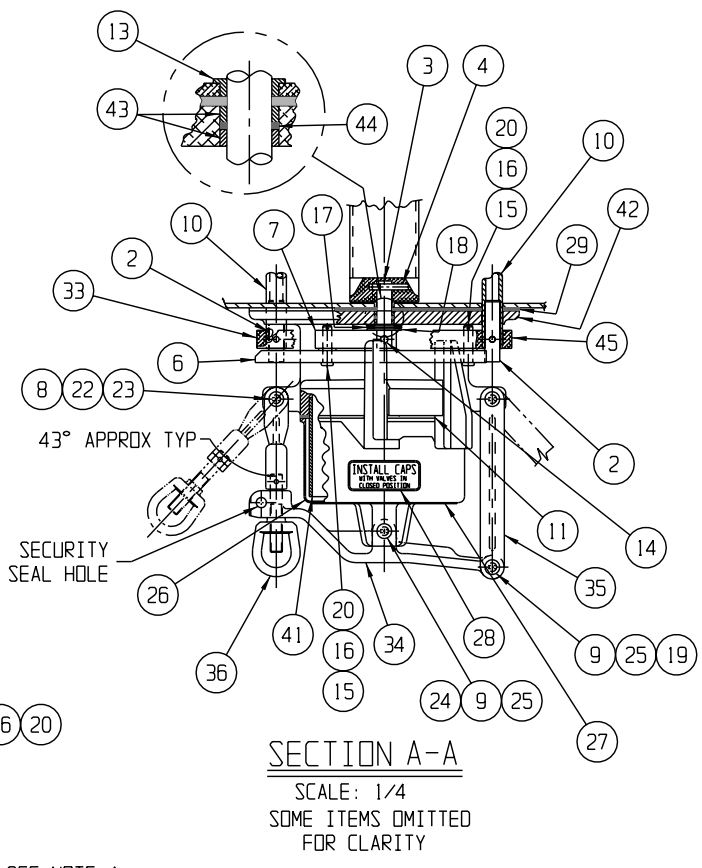
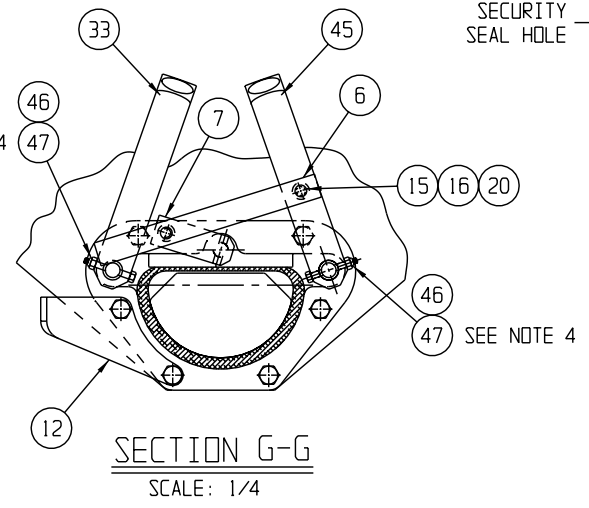
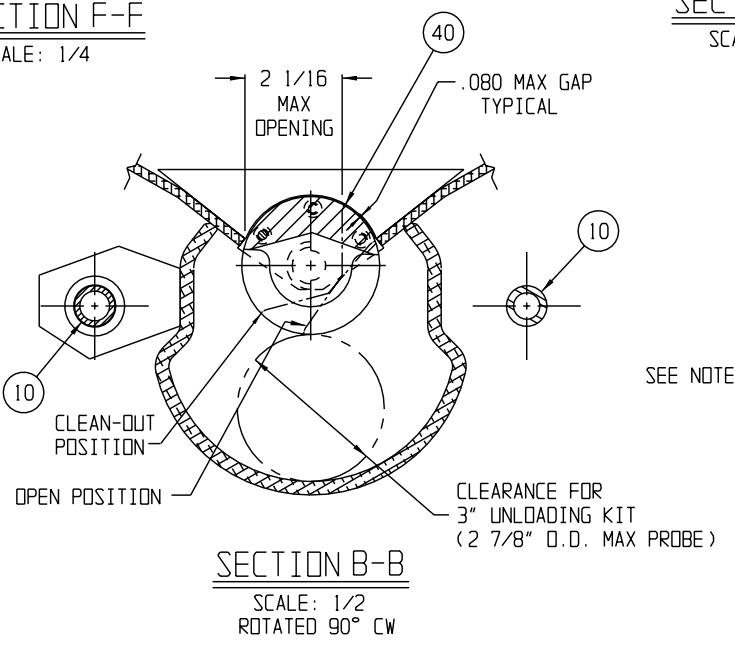
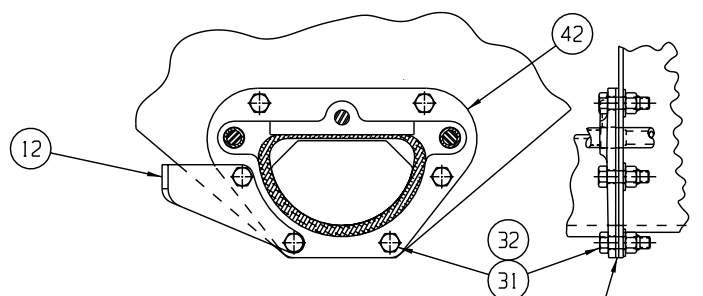
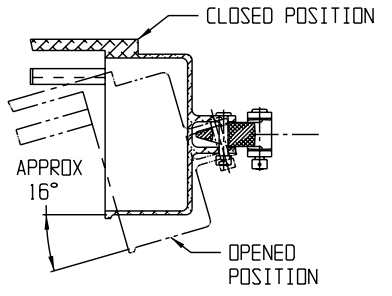
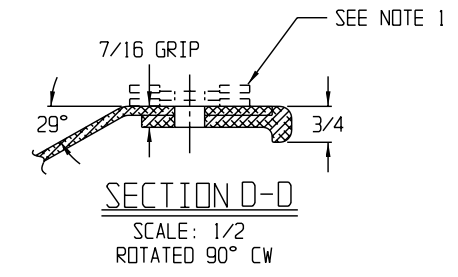
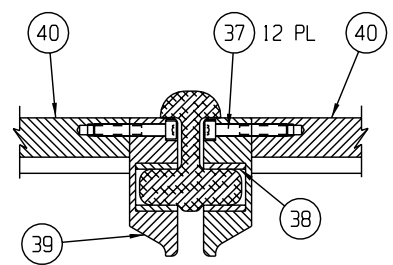
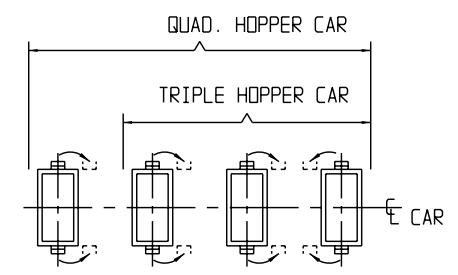

4	4493-43	LOCKNUT W/NYLON INSERT (1/4-20) - ZINC PLTD	47
4	3442-188	HEX HD CAP SCREW 1/4-20 X 2 ZINC PLTD, GRADE 5	46
2	34125-1	OPERATING LEVER R.H. - ALUMINUM	45
2	3918-48	O-RING - BUNA N	44
4	31693	BEARING - NYLON	43
2	30611	FLANGED CONNECTOR - ALUMINUM	42
2	7956	CONNECTOR TUBE - ST. STEEL	41
-	30727	FLANGED CONNECTOR ASSEMBLY	-
2	32465	VALVE TAPPED - ALUMINUM	40
2	32466-2	VALVE END, CENTER - ALUMINUM	39
2	32475	BEARING - NYLON	38
-	32476	VALVE END ASSEMBLY	-
12	3296-41	SCREW (1/4-20 X 1 1/4 S.H.C.S.) - ST. STEEL	37
-	33076	VALVE ASSEMBLY	-
2	31465	SIDE LINK & EYE BOLT ASS'Y - ALUMINUM	36
2	30488	PIVOT ARM - ALUMINUM	35
2	31479	LOCKING ARM - ALUMINUM	34
2	34125-2	OPERATING LEVER LH - ALUMINUM	33
12	3958-41	WASHER (1/2) - ST. STEEL	32
12	4493-22	NUT (ESNA) (1/2-13) - ZINC PLATED	31
12	3442-127	BOLT HEX HD. (1/2-13 X 1 3/4) - ZINC PLATED	30
2	30725	GASKET - NEOPRENE	29
2	33978	CAP INSTALLATION DECAL	28
2	30605	OUTLET CAP PLATE - ALUMINUM	27
2	32167	CAP - ALUMINUM	26
-	32165	CAP ASSEMBLY	-
4	32255-1	SPACER - DELRIN	25
2	32254-1	PIN (3/8 X 1 7/8) - ST. STEEL	24
4	32255-2	SPACER - DELRIN	23
4	32254-2	PIN (1/2 X 2 11/64 TO HOLE) - ST. STEEL	22
2	30956	NAMEPLATE ASSEMBLY - ALUMINUM	21
4	3958-44	WASHER (3/8) - ST. STEEL	20
2	32254-3	PIN (3/8 X 2 11/64 TO HOLE) - ST. STEEL	19
2	3958-46	WASHER (5/8) - ST. STEEL	18
6	8282	DISC SPRING - ZINC PLATED	17
4	4034-21	COTTER PIN (3/32 X 3/4) - ST. STEEL	16
4	7933-7	CLEVIS PIN (3/8 X 1 15/32 TO HOLE) - ST. STEEL	15
2	3206-23	GROOVED PIN (5/16 X 1 1/4) - ZINC PLATED	14
2	32485	BEARING - NYLON	13
2	34094	LEVER STOP	12
2	7837	END CAP GASKET - NEOPRENE	11
2	34095-2	OPERATING SHAFT - GALV.	10
4	3206-26	GROOVED PIN (1/8 X 5/8) - ST. STEEL	9
4	3206-28	GROOVED PIN (1/8 X 3/4) - ST. STEEL	8
2	30447-1	VALVE LEVER - ALUMINUM	7
2	30464-1	OPERATING LINK - ALUMINUM	6
2	32466-1	VALVE END - ALUMINUM	5
2	3206-18	GROOVED PIN (1/4 X 1 1/2) - ST. STEEL	4
2	32484	VALVE END SHAFT - ST. STEEL	3
-	33087	VALVE END ASSEMBLY	-
4	34096	OPERATING SHAFT END - ST. STEEL	2
1	8020	BODY ASSEMBLY - ALUMINUM	1

THIS DOCUMENT AND ITS CONTENTS CONTAIN CONFIDENTIAL AND PROPRIETARY INFORMATION OWNED BY ELLCON-NATIONAL, INC. AND IT AND ALL COPIES THEREOF ARE TO BE RETURNED TO ELLCON-NATIONAL WHEN SO REQUESTED. THIS DOCUMENT OR ANY PART THEREOF SHALL NOT BE REPRODUCED, COPIED, OR TRANSMITTED ELECTRONICALLY. THE INFORMATION CONTAINED HEREIN SHALL NOT BE DISCLOSED BY THE RECIPIENT TO OTHERS OR USED BY RECIPIENT WITHOUT THE PRIOR WRITTEN CONSENT SPECIFIC TO EACH CASE. ELLCON-NATIONAL, INC.

FOR TRINITY SG-3TG WORKING POINTS

ELLCON NATIONAL
 50 BEECHTREE BLVD. GREENVILLE, S.C. 29605

"NORSON"
 PNEUMATIC OUTLET

SCALE 1/8 & NOTED DATE 7/31/03 REV.
 DRAWN PS D-8030-20A A
 CHECKED

EST WT = 163 LBS

HAND STAMP SERIAL NO. HERE IN 3/16 HIGH CHARACTERS

CLEAN-OUT POSITION