

OPERATING INSTRUCTIONS FOR ELLCON-NATIONAL ANGLE AND STRAIGHT END COCKS:

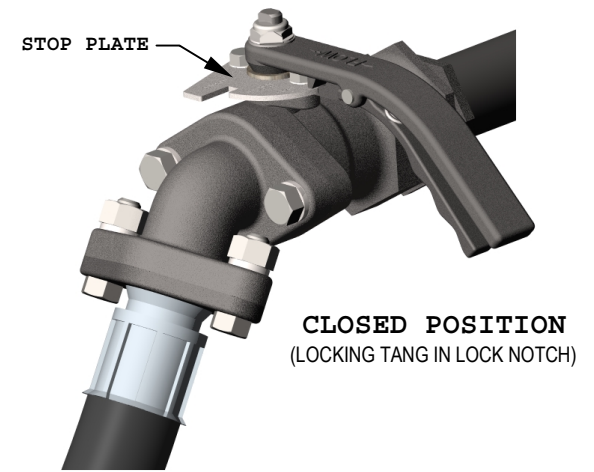

- 1) SQUEEZE SPRING LOADED HANDLE ASSEMBLY TO CLEAR LOCK-NOTCH ON STOP PLATE AND START MOVING HANDLE ASSEMBLY.
- 2) ONCE CLEAR OF LOCK-NOTCH, RELEASE LOCKING LEVER AND SLIDE HANDLE ASSEMBLY TO OPPOSITE LOCK-NOTCH.
- 3) TRY MOVING HANDLE (DO NOT SQUEEZE) TO VERIFY THAT IT IS PROPERLY LOCKED.

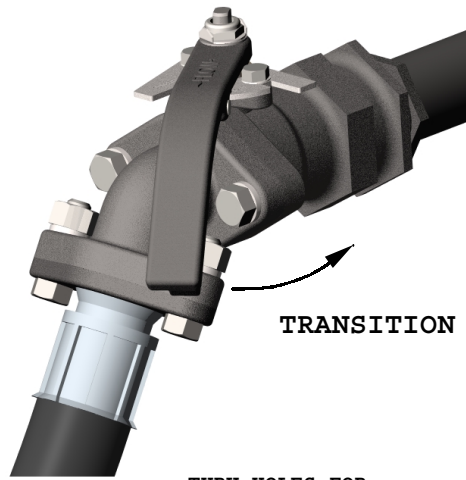
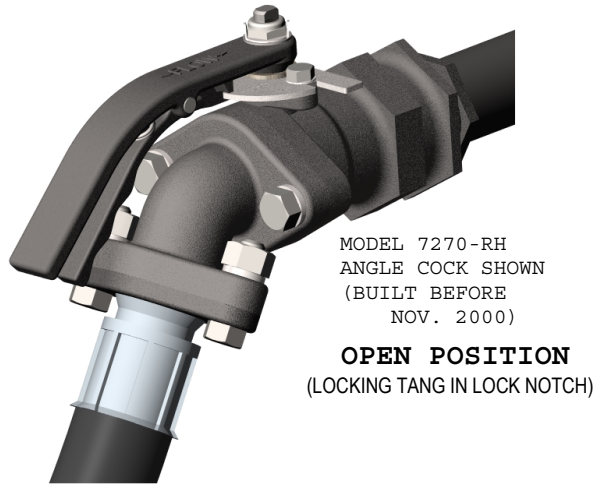
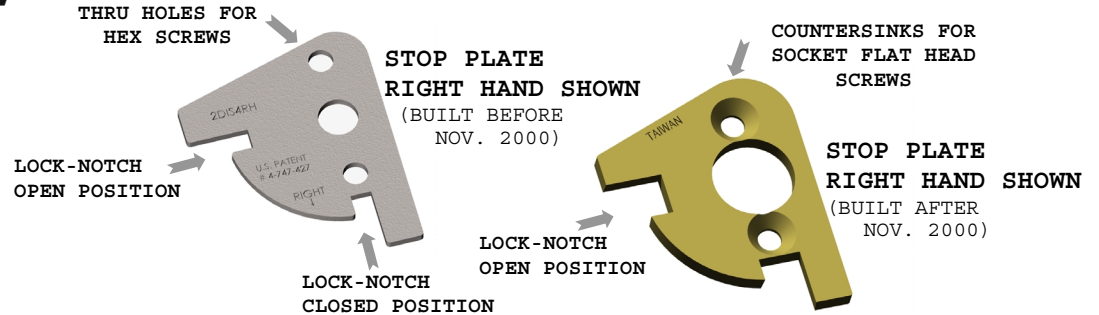

INSPECTION CRITERIA:

- A) IF HANDLE CAN BE MOVED FROM THE OPEN OR CLOSED POSITION WITHOUT SQUEEZING LOCKING LEVER, THEN REPLACE WITH HANDLE ASSEMBLY TORQUE KIT.
- B) IF HANDLE, LOCKING LEVER, OR SPRING IS MISSING OR DAMAGED THEN REPLACE WITH HANDLE ASSEMBLY TORQUE KIT.
- C) IF ROLL PIN IS PROTRUDING FROM HANDLE 1/8" OR MORE ON UNITS BUILT BEFORE FEB. 1996 THEN REPLACE WITH HANDLE ASSEMBLY TORQUE KIT.
- D) IF LOCKING TANG OR STOP PLATE IS WORN MORE THAN 1/8" INCH THEN REPLACE WITH HANDLE ASSEMBLY TORQUE KIT.

HANDLE ASSEMBLY TORQUE KITS:

ANGLE COCK -P/N 33890-1 LEFT HAND
 P/N 33890-2 RIGHT HAND
 STRAIGHT END COCK -P/N 34270-1 LEFT HAND
 P/N 34270-2 RIGHT HAND
 FOR UPGRADE INSTRUCTIONS SEE FORM 108.

FORM 107

Rev B
 03/28/01

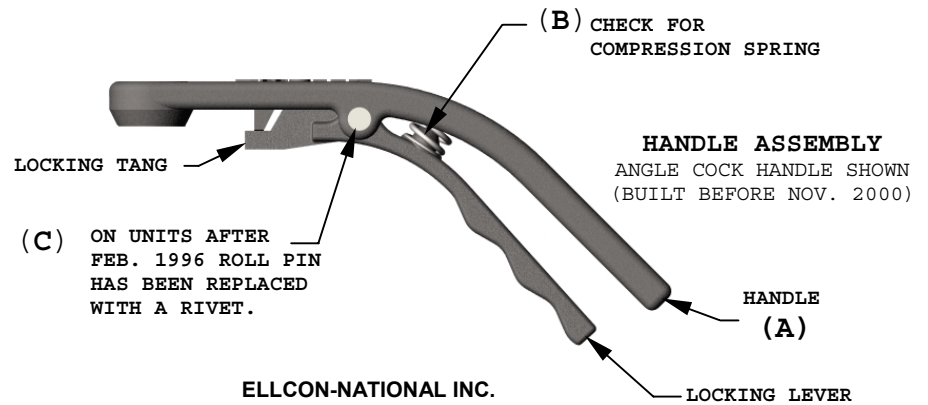

ELLCON-NATIONAL INC.
 50 BEECHTREE BLVD.
 GREENVILLE, SC 29605
 PHONE (864)277-5000
 FAX (864)277-5207
 www.ellcon-national.com